

Status Report with respect to Measurements, Modelling and Emissions of Particulate Matter in EMEP: An integrated approach

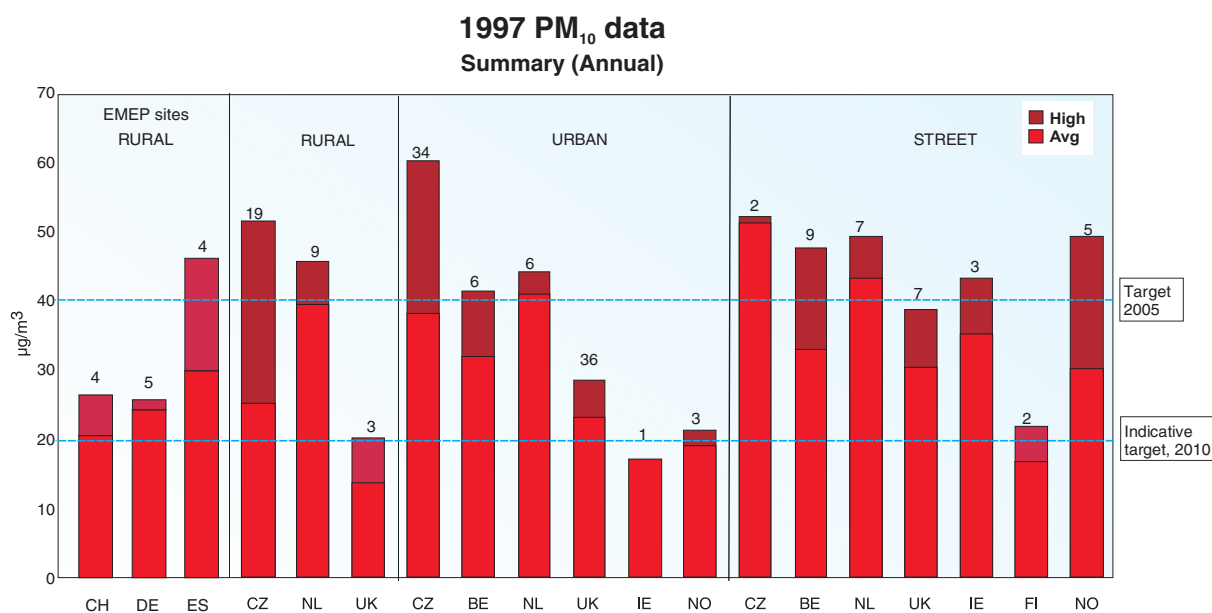

NILU: EMEP Report 5/2000
REFERENCE: O-98134
DATE: AUGUST 2000

**EMEP Co-operative Programme for Monitoring and Evaluation of the Long-
Range Transmission of Air Pollutants
in Europe**

**Status Report with respect to
Measurements, Modelling and Emissions
of Particulate Matter in EMEP:
An integrated approach**

**Joint
CCC & MSC-W
Report 2000**



Norwegian Institute for Air Research
P.O. Box 100, N-2027 Kjeller, Norway



DNMI

Norwegian Meteorological Institute
P.O. Box 43 Blindern, N-0313 Oslo, Norway

List of Contributors

Mihalis Lazaridis¹,
Arne Semb¹,
Jozef Pacyna¹,
Øystein Hov¹,
Jan Schaug¹,
Steinar Larssen¹,

Leonor Tarrasón²,
Svetlana Tsyro²,
David Simpson²,
Krzysztof Olendrzyński²,
Yvonne Andersson-Sköld³

¹ EMEP Chemical Coordinating Centre
² EMEP Meteorological synthesizing Centre
³ Melica, Fjällgatan 3e, Göteborg, Sweden

Contents

	Page
List of Contributors	3
1. Introduction	7
2. Overview on particulate matter measurements in Europe	9
2.1 Particulate matter measurements and chemical composition of PM inside the EMEP Framework.....	9
2.2 Initial recommendations for monitoring particulate matter in EMEP	13
2.2.1 Concentrations of particulate matter with gravimetric methods	15
2.2.2 Chemical speciation.....	16
3. Modelled estimates of particulate matter in Europe	19
3.1 Short models description	19
3.2 Calculated concentrations of particulate matter in Europe.....	21
3.3 Comparison with observations	24
3.4 Uncertainties in BSOA calculations.....	28
3.5 The influence of emission changes in primary PM	29
3.6 Recommendations for further model development	32
4. An assessment of particle emissions in Europe	35
5. References	39

1. Introduction

Particulate Matter (PM) research presents a new challenge to the transboundary air pollution strategies in Europe. Airborne particulate matter is a complex mixture of many different chemical species originating from a variety of sources with sizes ranging from few nanometers to several hundred micrometers (Finlayson-Pitts and Pitts, 1986; Seinfeld and Pandis, 1998; EPA, 1996; EU-Position Paper on Particles, 1998). This complexity has implications also for the multiplicity of their effects. Particulate matter is important as vector of transport and deposition of sulphur, nitrate, ammonium, heavy metals, and persistent organic products, and efficiently contributes to visibility problems (Schaug and Uhse, 1997; EPA, 1996; EU, 1996, 1997). The increased concern for particulate matter is primarily related to their recognised adverse effects on public health (EPA, 1996; WHO, 1999), sensitive ecosystems and climate (Andreae and Crutzen, 1997).

Recent research studies strongly support the significant contribution of the PM long-range transport component to the regional particle mass and number size distribution. This is a consequence of the atmospheric residence time of PM that is ranging from few days to few weeks. The relative importance of long-range transport of particulate matter also justifies the observed small differences in the average total mass of PM_{2.5} between urban and non-urban continental aerosols (Heintzenberg, 1989). The evidence of the role of long-range transport of particulate matter and its significant associations with a wide range of adverse health effects (WMO-EMEP, 1999) has urged the inclusion of particulate matter within the EMEP framework.

The EMEP programme can contribute to the development and implementation of emission reduction strategies for particulate matter at European level. For its results to be useful, EMEP needs to anticipate the requirements for a meaningful assessment of adverse health effects. There is a high degree of uncertainty about what are the properties of atmospheric aerosol that actually determine the hazardous health effects. Still, the discussion concerns mostly the following characteristics:

- Particulate matter air concentrations, in particular for particles with aerodynamic diameter smaller than 10 µm,
- the chemical composition of the aerosol,
- the size distribution of the aerosol, as it influences the extent to which particles penetrate into the respiratory tract.

Consequently, the basic elements of the EMEP programme: compilation and evaluation of emission, measurement and transboundary exchange data and review of information on the potential and costs for controlling emissions, need to be organised to allow for the characterisation of mass, size and chemical composition of the aerosol and facilitate the assessment of the effects.

In this way, the basic information compiled by EMEP will be able to support the development of emission reduction strategies also as new information on the factors contributing to health effects becomes available.

The determination of aerosol mass, chemical composition and size distribution has been the main concern of the discussions at the EMEP/WMO Workshop on Fine Particulates: Emissions, Measurement and Modelling, held in Interlaken, Switzerland, 22-25 November 1999 (EB.AIR/GE.1/2000/9). It is also the main purpose of this first EMEP summary report for particulate matter, where European scale data availability in terms of measurements, modelled calculations and emission inventories is considered and reviewed.

Measurement methods for PM are available, both for total particulate matter and for specific chemical components, but only limited results are yet available at European level (Lazaridis et al., 1999). Results show that the difference between rural and urban concentration levels is rather small. This is particularly the case in continental Europe. Harmonised measurements of PM₁₀ and more detailed chemical analyses of the particulate matter contribution to PM₁₀ and PM_{2.5} are required to support the formulation of environmental policies to reduce ambient PM concentrations. At present, however, differences in measurements of PM due to the use of different sampling and analytical methods mask the possibility of deriving significant spatial variations in Europe from otherwise scarce data.

The same limitations apply to the determination of the chemical composition of the aerosol. The chemical analyses needs to distinguish at least: secondary inorganic aerosols, elemental carbon, organic carbon, sea salt and crustal dust. Total particulate sulphate and nitrate are the dominant components, with ammonium nitrate prevailing in western Europe and particulate sulphate (mainly as ammonium sulphate) prevailing in eastern Europe (see Van der Zee et al., 1998; Zappoli et al., 1999). Together with secondary inorganic, primary aerosols, largely organic and elemental carbon, minerals and crustal material, explain a major part of the particulate mass concentration levels in Europe. Recent studies (e.g. Heintzenberg et al., 1998) emphasise the importance of organic compounds, whereas minerals from fly ash have apparently decreased strongly in the last years.

In this report, a preliminary emission inventory for the whole European region (TNO, 1997) has been used for an initial appraisal of the emissions of primary particulate emissions from anthropogenic sources for use in the EMEP modelling studies. In collaboration with the European Environmental Agency, EMEP has taken steps to improve this emission inventory, and to update the estimates to the present situation. The preliminary emission estimates need to be refined, particularly with respect to chemical composition of the primary particles from different source categories. The final emission data will also require active participation from research groups at all European countries.

Using TNOs emission inventory, the fraction resulting from primary anthropogenic emissions of particulate matter has been estimated and compared to the contribution from secondary inorganic aerosols and secondary organic aerosol from biogenic emissions. Comparison of modelled PM concentrations and chemical composition with observations has shown the need for further studies on secondary organic aerosol formation and the quantification of SOA in Europe. Future improvements in the EMEP modelling framework should include interactions between different components of aerosol particulate matter, formation of secondary aerosol particles and growth of particles by coagulation and condensation processes, since these influence size distributions and deposition processes.

2. Overview on particulate matter measurements in Europe

by Mihalis Lazaridis, Arne Semb, Steinar Larssen, Øystein Hov and Jan Schaug

Measurement methods for PM are available, both for total particulate matter and for specific chemical components, but limited results are as yet available in European level (Lazaridis et al., 1999). In this chapter, an overview is presented on available measurements of particulate matter in Europe and the information these provide with regard to PM air concentrations and chemical composition. In addition, an initial effort is made to formulate recommendations for a meaningful measurement network within EMEP.

2.1 Particulate matter measurements and chemical composition of PM inside the EMEP Framework

Only Switzerland, Germany and Spain report measured concentrations of suspended particulate matter at their EMEP stations in 1997, using gravimetric measurement methods. Annual averages at those sites are presented in Table 2.1 below.

Table 2.1: Measured aerosol particle concentrations at some EMEP sites.

Site	SPM, $\mu\text{g}/\text{m}^3$	Method
CH01 Jungfrauoch	3.5	PM ₁₀
CH02 Payerne	26.3	
CH03 Tänikon	27.3	
CH04 Chaumont	13.9	
CH05 Rigi	14.4	
DE01 Westerland	26.2	LIS
DE02 Waldhof	24.3	
DE03 Schauinsland	13.3	
DE04 Deuselbach	20.7	
DE05 Brotjacklriegel	15.4	
DE07 Neuglobsow	23.1	
DE08 Schmücke	17.3	
DE09 Zingst	23.8	
ES01 Toledo	19.7	
ES03 Roquetas	44.4	
ES04 Logrono	33.0	
ES05 Noya	24.5	
ES06 Mahon	28.4	
ES07 Viznar	30.9	
IT04 Ispra	46.8	
NL02 Witteven	(35)	β -abs.
NL10 Vreedepeel	(44)	β -abs.
SE12 Aspvreten	(9.5)	TEOM

The measured values may not be directly comparable, because of different measurement methods and procedures. This is partly because of differences in the

air intakes, but also because of other sampling artefacts, particularly evaporation of ammonium nitrate and other volatile constituents from filters during sampling. This is particularly serious in the heated filters used in TEOM and β -absorption instruments (Allen et al., 1997, Patashnik, 1998).

Few sites reporting TSP or PM₁₀ carry out the full measurement programme of EMEP. Sulphate is determined at the majority of the sites, ammonium and nitrate are reported only as the sum of ammonia and ammonium, and the sum of nitrate and nitric acid, respectively. However, experience has shown that ammonium associated with particles is generally explained as ammonium sulphate and ammonium nitrate. This may not be entirely justified, particularly not in Spain, where a significant fraction of both sulphate and nitrate may also be associated with alkaline soil dust particles. The ratio of nitrate associated with particles to the sum of nitrate and (gaseous) nitric acid has been studied in measurement campaigns carried out within EMEP in 1993 (also Figure 2.1) (Semb et al., 1998).

The results show that the fraction of gaseous nitric acid is typically 20-30%, relative to the sum of nitrate and nitric acid. The lowest relative concentration of nitric acid is found in areas with high ground-level concentrations of ammonia, and relatively low temperatures. It was found that ammonia was not generally limiting the formation of ammonium nitrate, since sulphur dioxide emissions and sulphate concentrations have been reduced.

There is relatively good correlation between observed TSP concentrations and concentrations of aerosol sulphate (and nitrate) at many of the sites, even if the sulphate and nitrate concentrations account only for 20%-40% of the aerosol mass. This indicates that the aerosol particle mass concentrations are part of long-range transported or regional air pollution components, which also includes particles which are emitted from various anthropogenic sources, such as stationary combustion sources, mobile sources and industrial processes.

Closing the mass balance also requires the determination of elementary carbon and organic compounds. The latter consist of very many individual compounds, and the identified compounds or groups of compounds only account for some 15-20% of the organic fraction (e.g. Rogge et al., 1993; Lioussé et al., 1993). Elementary carbon is typically 5-10% of total carbon. Examples of chemical composition of fine particles at three rural stations, in Italy, Hungary and Sweden are given by Zappoli et al., 1999. Two of these sites (K-puszta and Aspvreten) are also EMEP sites. Care should be taken with respect to the representativeness of these results, since they only represent 2 months of sampling at three sites. The contribution of both water-soluble and insoluble organic carbon to the fine particulate mass is remarkably high. A very high contribution of water-soluble organic carbon to the mass at Aspvreten may be related to the time of the year and the low fine particulate mass concentration. The measurements were carried out during summer with a high production of natural organic compounds and relatively low anthropogenic contributions.

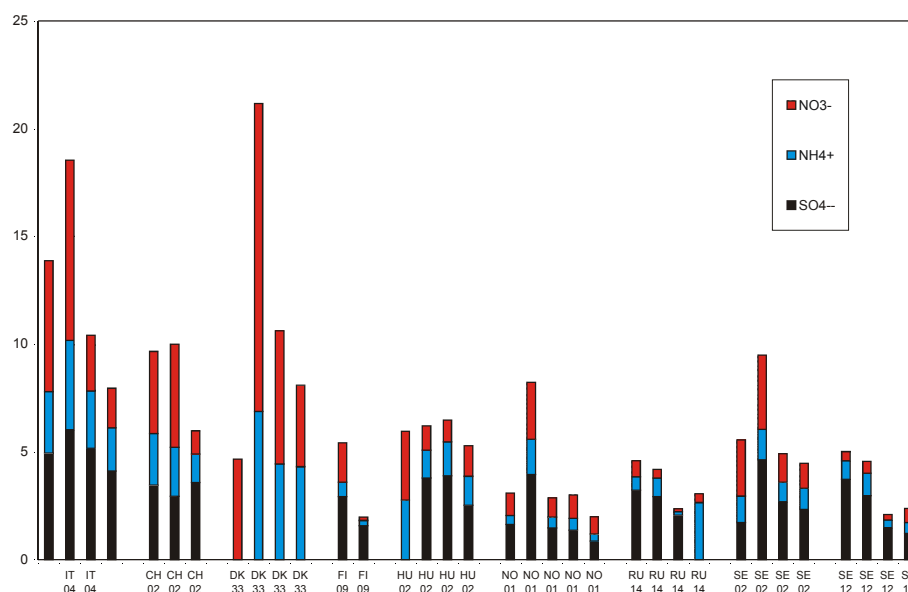

Figure 2.1: Concentrations of particulate sulphate, nitrate and ammonium from denuder measurements during the EMEP measurement campaign. Measurements were performed for periods of 4-5 weeks. Concentrations are given in weight equivalents for comparison with PM_{10} concentration levels.

The importance of organic compounds for the particulate mass is also emphasised by Heintzenberg et al. (1998), who reported on extensive measurements from Melpitz, near Leipzig in south-eastern Germany. The concentration of coarse particles consisting mainly of inorganic minerals and fly ash particles has decreased strongly since 1993, and now represent only about 20% of total particulate mass, or PM_{10} .

The content of organic materials in aerosol particles and their relationship with both primary emissions and atmospheric processes is a considerable challenge, more so because the other components of atmospheric particulate matter are declining because of emission reductions. Heintzenberg et al. (1998) find that the fine aerosols (<1–2 μm) consist almost exclusively of organic and secondary inorganic particulate material.

Previous studies indicate (Semb et al., 1995; see also Figures 2.2–2.3) that the contribution from secondary inorganic aerosol components, viz. ammonium sulphate and ammonium nitrate, is between 20 and 40%. The contribution of 30% is found typical of Northern Europe. Figure 2.2 presents annual average values for the period 1973–1993 from the Norwegian station in Birkenes, whereas Figure 2.3 shows time series data from the same station between 1991 and 1995. If the sampling was restricted to fine particles, i.e. particles less than 2.5 μm diameter, the weight percentage of the secondary inorganic aerosol component should increase.

Methods used to obtain aerosol mass concentrations by sampling on filters will always to some extent be ambiguous. Loss of volatile species during sampling has been mentioned, another artefact is related to water uptake by deliquescent salts. Most water-soluble inorganic salts will take up water at relative humidity above

60-70%, and aerosols will usually contain substantial amounts of water, which will be retained even at lower relative humidity, because crystallisation of the pure salts is inhibited.

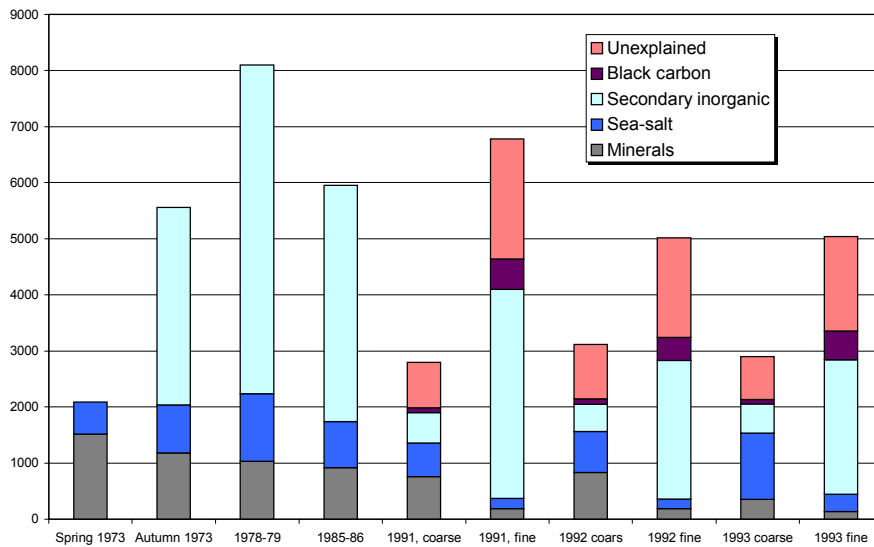

Figure 2.2: Chemical speciation (ng/m^3) of suspended particulate matter in Birkenes (Norway) in the 1973-1993 time period.

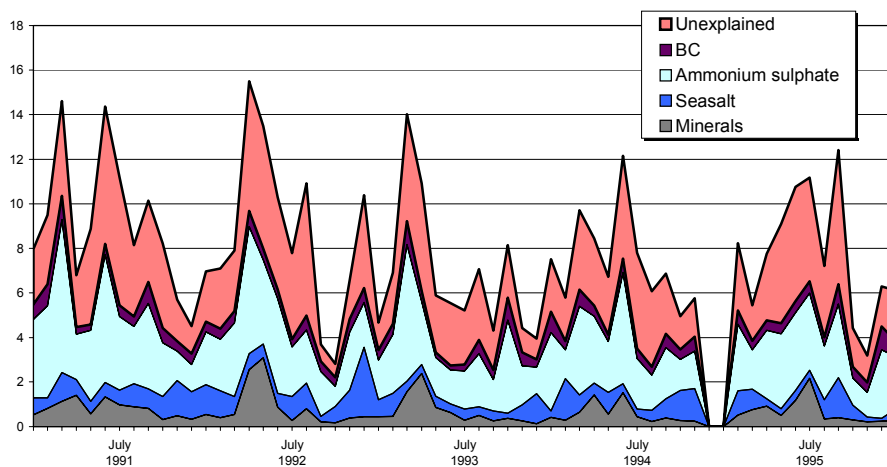

Figure 2.3: Measured PM_{10} mass concentrations at Birkenes for the period February 1991-February 1996, together with inferred masses of specific components from chemical analyses. ($\mu\text{g}/\text{m}^3$).

Full chemical analysis of particles sampled on filters is also not straightforward, mainly because of the many different organic compounds. It is possible to determine some key components, which may be valuable if these components are specific indicators of important emission categories or processes. Determination of carbon following stage-wise thermodesorption and oxidation may be used to quantify the amounts of elementary and organic carbon (e.g. Cachier et al., 1997). It is more technically demanding to separate different classes of compounds by selective extraction. The fraction of the organic compounds which is water-soluble may be quantified in this way, however.

Good analytical methods exist for the determination of inorganic elements, and there is a large body of information concerning the inorganic elemental composition of aerosol particles, dating from the 1970's. (e.g. Pacyna et al., 1984; Lannefors et al., 1983; Amundsen et al., 1992; Pakkanen et al., 1996). These studies also show, however, that the concentration of inorganic minerals in aerosols have declined over this period.

The European Topic Centre on Air Quality (ETC-AQ), under contract from EEA (European Environment Agency) is managing the database system AIRBASE. Air quality data from a large number of monitoring stations are stored in AIRBASE. Figure 2.4 presents the measured levels of PM₁₀ at rural, urban and roadside sites. Data from rural areas are from both the AIRBASE and EMEP databases. Different measurement methods have been used to quantify the particulate mass concentration levels on Figure 2.4. The term "high" refers to the highest value among the stations. The Netherlands and the Czech Republic use beta-gauges, United Kingdom uses TEOM instruments. Both beta-ray absorption monitors and TEOM give low results compared to the CEN 12341 gravimetric reference method for PM₁₀, the Netherlands uses a constant factor to correct for this. However, the Figure clearly shows that the rural concentration levels of particulate mass are not much lower (10-30%) than the urban and roadside concentrations.

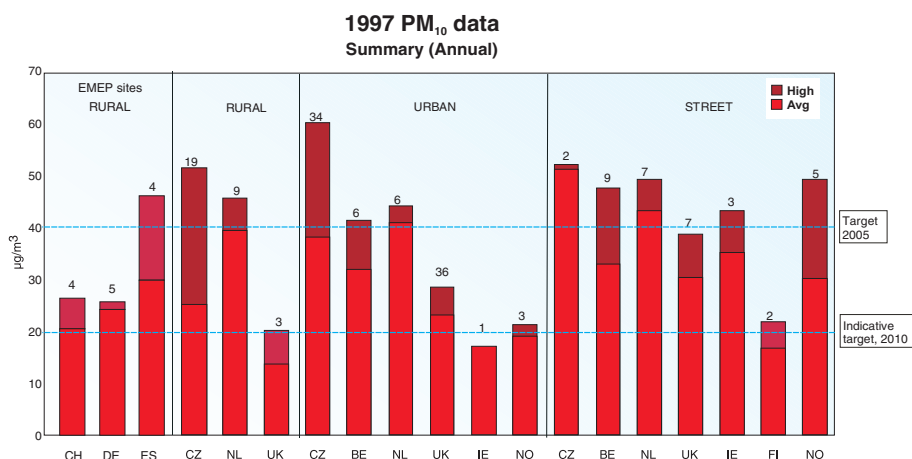

Figure 2.4: Annual averages of the PM₁₀ concentrations in different countries in Europe.

2.2 Initial recommendations for monitoring particulate matter in EMEP

There has been given a number of recommendations for PM monitoring inside the EMEP framework during the EMEP-WMO meeting in Interlaken (EMEP, 1999). Topics such as the geographical coverage of the monitoring stations, the type of measurements (PM (mass) and chemical composition), the temporal coverage and recommended sampling and analysis methodology were considered.

The main recommendations from the EMEP-WMO meeting in Interlaken concerning PM measurements were the following:

1. EMEP should give first priority to PM₁₀ measurements. For this purpose the gravimetric method is the preferred method, particularly because the filters allow subsequent chemical analysis for quantification of different compounds. Monitors are acceptable if they have been shown to deliver equivalent results for the specific site and for all seasons.
2. EMEP sites should also determine secondary inorganic particulate matter, i.e. ammonium sulphate and ammonium nitrate, as well as other water-soluble ions when these make up a significant part of PM₁₀ mass.
3. Measurements of particles with an aerodynamic diameter less than 2.5 or 1 µm should be carried out in the near future when the definition of the European reference method is in place.
4. For chemical characterization, determination of elemental and organic carbon is highly desirable. The subsequent determination of organic and elemental carbon by thermodesorption and oxidation is subject to artefacts, and care has to be taken to avoid results that are not comparable. There are also sampling artefacts related to organic compounds. EMEP will need to consult with other bodies on these issues. If they can be resolved, centralized laboratories for the determination of elemental and organic carbon should be established for the analysis of samples from EMEP sites.
5. More detailed size fractionated chemical speciation would be desirable and should be done in the context of scientific projects.
6. “Superstations” should be set up together with other scientific organizations and programmes. These could be used for a number of chemical and physical measurements that go beyond the scope of the “normal” EMEP site, e.g. for determination of some of the organic compounds, size distribution, detailed size fractionated chemical speciation, optical properties, water uptake, cloud condensation nuclei, vertical distribution and better time resolution (1 hour) for certain parameters.
7. EMEP welcomes closer collaboration with other international initiatives, such as the Global Atmospheric Watch (GAW) of the World Meteorological Organization (WMO) and EUROTRAC, as well as national programmes. This collaboration would concern both measurements and modelling, in particular the EUROTRAC subproject AEROSOL. It would accelerate the exchange of scientific and technical information and improve understanding between EUROTRAC and EMEP.
8. EMEP and WMO see a large potential for collaboration in the fine particulate programme. Many measurement sites in Europe are already both EMEP and GAW sites. This could still be extended. In particular, global GAW stations could possibly be designated as “superstations” within EMEP (see para. 15 above). It is expected that the newly formed Task Force on Measurements and Modelling, which is co-chaired by Austria and WMO, will be best suited to address this task. These joint activities at common sites will help to produce more comprehensive results.
9. The EMEP/CCC website (<http://www.emep.int>) should be used to share information on ongoing and planned research and intercomparison of measurement techniques.

In the next subsections a more detailed discussion on gravimetric measurements and consequently chemical analysis is presented.

2.2.1 Concentrations of particulate matter with gravimetric methods

A number of different methods have been used to quantify the concentration of particulate matter in ambient air. These may either be based on the sampling of air through a suitable filter and subsequent weighing, or on other methods, such as by monitoring the absorption of β -radiation through the filter, or the monitoring of frequency of an oscillating tapered element with a filter at the tip. Other methods are based on light scattering, or counting of particles with different mass through electrical charging and determining their mobilities. All these methods can and will give different results, and the European Standardisation Organisation has therefore designed three different reference methods for determination of the mass of particulate matter with aerodynamic equivalent diameter smaller than $10\ \mu\text{m}$ (CEN, 1998). Methods for the measurements of particulate mass and results from comparative testing of different methods have been reviewed in a workshop meeting by the WHO (1999).

Direct recording instruments can be used if they have been shown to provide consistent results compared with gravimetric methods. The main problem with the monitoring instruments is that heating to remove water contained in the aerosol particles will also lead to the evaporation of ammonium nitrate and volatile organic compounds. When these substances constitute a large fraction of the aerosol mass, some of the monitoring instruments will give erroneously low readings. The gravimetric method will also be subject to sampling artefacts, and losses of ammonium nitrate may also occur when filters are suspended in a weighing room for 48 hours at 25 degrees C and 50% R.H. These artefacts will be addressed in separate tests and investigations that are now going on in several European countries, and in the preparations for a new European $\text{PM}_{2.5}$ standard.

Following the recommendations made in the Interlaken meeting (EMEP, 1999) the EMEP should give first priority to PM_{10} measurements. For this purpose the gravimetric method is the preferred method, particularly because the filters allow subsequent chemical analysis for quantification of different compounds. Monitors are acceptable if they have been shown to deliver equivalent results for the specific site and for all seasons. EMEP sites should also determine secondary inorganic particulate matter, i.e. ammonium sulphate and ammonium nitrate, as well as other water-soluble ions when these make up a significant part of PM_{10} mass.

According to Community Directive 96/62/EC on ambient air quality assessment and management and Directive 1999/30/EC relating to the establishment of limit values, inter alia also for particulate matter, all member states of the EU are obliged to report PM_{10} and $\text{PM}_{2.5}$ data. In order to assess air quality across Europe on a consistent basis the measurements need to be performed with standardized techniques. Therefore the European Commission has mandated the European Standardisation Committee (CEN) to establish reference methods for measurement of PM_{10} and $\text{PM}_{2.5}$ and to define requirements for alternative methods to be considered as equivalent methods.

A detailed description of the proposed reference method for PM₁₀ measurements is presented in the report by Lazaridis et al. (2000) where the EN12341 method is presented based on a report by the European Committee for standardization (CEN, 1998). The gravimetric method consists of a PM₁₀ sampling inlet, directly coupled with a filter substrate and a regulated flow device. The PM₁₀ mass collected on the filter can be determined gravimetrically. Filters have to be weighted before and after sampling.

Either a low- (Low Volume system: the LVS-PM₁₀ sampler, see Figure 2.5), high- (High Volume system: the HVS-PM₁₀ sampler) or superhigh- (Superhigh Volume system: the WRAC-PM₁₀ sampler) volume system can be employed. For compatibility other sampling equipment must have PM₁₀ inlet, constant flow and precision of sample volume measurement better than $\pm 3\%$.

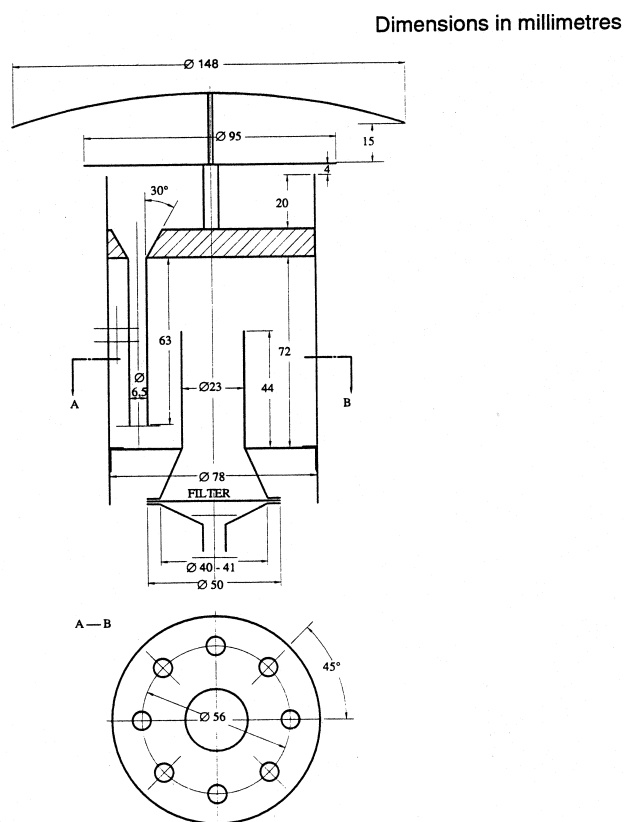

Figure 2.5: Design of 2,3 m³/h LVS-PM₁₀ sampling inlet (CEN, 1998).

The three methods are all recommended reference methods. CEN and EU also specify that alternative methods have to be tested in co-located measurements at sites representative of where these methods are to be used, and that their precision should be at least $\pm 3\%$. The testing requirement also specifies how results from alternative measurements should be corrected with a constant factor.

2.2.2 Chemical speciation

Following the recommendations from the Interlaken Meeting (EMEP, 1999) chemical constituents of the aerosol mass collected on the filter can be analysed for determining:

- Water-soluble inorganic components: Analyses of extracts from PM₁₀ filters, or separate sampling. Chemical speciation should primarily include determination of sulphate, nitrate, ammonium and other water-soluble ions in filter samples. The latter will include sea-salt, which contributes significantly to the PM₁₀ in coastal regions in western Europe. Analysis for the water-insoluble inorganic components is not recommended. Loss of ammonium nitrate and other volatile species is definitely an important concern during the weighting procedure.
- Elementary carbon: Elementary carbon should be determined together with organic carbon.
- Determination of specific organic compounds or groups of compounds: Up to 4000 individual organic compounds may be identified following liquid extraction from a sample of atmospheric aerosol particles. Together, these are not likely to explain more than 40% of the organic carbon. Although insignificant in connection with total mass, some of the individual organic compounds may be valuable quantitative indicators of important emission sources or processes, e.g. burning of biomass or formation of secondary organic particulate matter. Determination of individual compounds will be regarded as a research activity until such relationships are proven and found valuable on European basis.

In the current EMEP measurement programme water-soluble ions (SO₄⁻, NO₃⁻, and NH₄⁺) collected on filters are already reported. In some cases, only the sums of NO₃⁻ and HNO₃ and of NH₄⁺ and NH₃ are reported. However, since the aerosol filters and the impregnated filters are separately leached and analysed, NO₃⁻ and NH₄⁺ should be reported separately also in these cases. It is assumed that sampling artefacts are the same for all filter collection methods. Leaching and ion chromatographic analysis of the extracts from the aerosol filter will also give data for sea-salt aerosol, calcium and potassium. Analysis of an aqueous extract from the quartz fibre filter is then only required as a check of the consistency of the sampling and the results, and particularly to check if there is significant loss of ammonium nitrate during the “conditioning” procedure. Alternatively, the weighed PM₁₀ filters may be leached and analysed. It is most convenient to punch a smaller part of the sample filter for such analyses. The chemical analysis is straightforward, but care has to be taken to avoid clogging of the ion chromatograph with quartz fibres.

The quantification of elementary carbon and organic compounds (EC/OC) in aerosol particles is of considerable interest for the understanding of their primary sources and due to their different hygroscopic properties that affect their physical properties. Elementary carbon is present in the form of chain aggregates of small soot globules, and is responsible for the light absorption of the material collected on filters. Unfortunately this light absorption depends on the size distribution of the soot particles and on the association of the soot particles with other substances in the aerosol particles and on sample filters. Optical methods to determine EC are therefore only semi-quantitative, and calibration factors may vary from one situation to another (e.g. Lioussé et al., 1993).

Figure 2.6 presents a chemical balance closure for aerosol concentrations in Italy. These results were taken from a recently published scientific paper (Zappoli et.

al., 1999) and are derived from sampling fine particles ($d_p < 1 \mu\text{m}$) at a site in the Po valley for a period of two months in 1997. Because of this, care should be taken not to regard these results as representative of a longer period or other regions in Europe. The results indicate that the composition is complex, emphasising the importance of the secondary inorganic component (SO_4^- , NO_3^- , NH_4^+) and the water-soluble and water-insoluble organic components. The high relative proportion of water soluble organic components may be a result of secondary organic aerosol formation. It is apparent that the chemical speciation is important for understanding the PM properties and trends in conjunction with their size distribution.

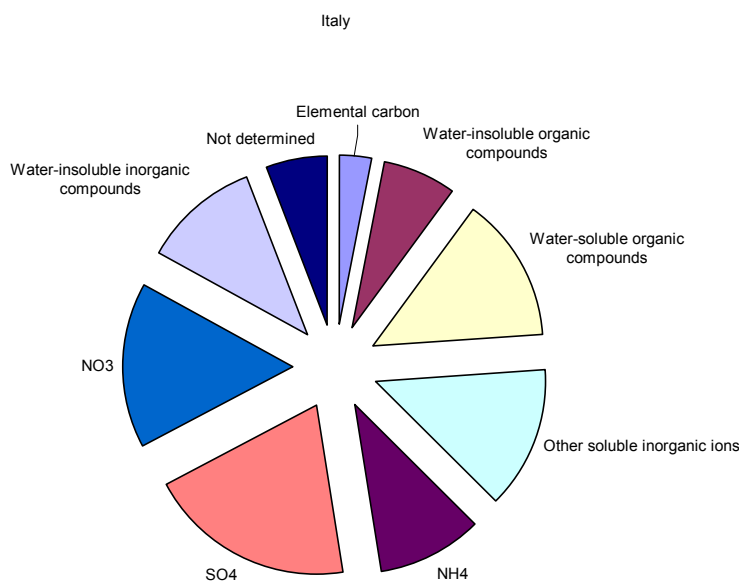

Figure 2.6: Chemical balance on element constituents of aerosol mass in Italy (Zappoli et. al., 1999).

These components are not sufficient to determine the full chemical mass balance. For this purpose, it is also necessary to include also the hydrogen, oxygen, nitrogen and other elements associated with the carbon in the organic fraction. Experience also indicates that some water is associated with the water-soluble fraction even after conditioning at 50% r.h. However, by multiplying the organic carbon with a factor of 1.4, and calculating the full weight of all the other components, reasonable agreement with the PM_{10} figure should be attained.

In addition, more detailed characterisation of the organic fraction, particularly in relation to different sources of organic particulate material (e.g. combustion, secondary organic particulate formation from both natural and anthropogenic VOC emissions can be most useful for the determination of sources and the relative weight of biogenic versus anthropogenic contributions.

3. Modelled estimates of particulate matter in Europe

by Leonor Tarrasón, Svetlana Tsyro, David Simpson, Yvonne Andersson-Sköld, and Krzysztof Olendrzyński

The impact on human health by atmospheric particles has been the recognised driving force for the extension of EMEP framework to include particulate matter. The preliminary assessment by WHO-EMEP on the Health Risk of Particulate Matter from Long-Range Transboundary Air Pollution concluded that there is significant association between the long-range component of particulate matter, measured as PM₁₀, and a wide range of adverse health effects (WHO-EMEP, 1999). This implies that valid first approximation for the study of the health impact of atmospheric particles can be dependant only on the total mass of PM₁₀.

EMEP should secure that the technical information to support policy development covers the possibility for dependencies on chemical composition and aerosol size distribution as well. However, it is important to analyse the feasibility for an assessment based on the direct relation with the total mass of PM₁₀.

In this chapter we investigate further the availability of relevant data for the study of the health effects associated to particulate matter mass over Europe. We have identified the main contributors to averaged mass concentrations as:

- a) secondary inorganic particles (SIA), that is, sulphates, nitrates and ammonium,
- b) primary particulate matter (PPM), mostly crustal dust, organic and elemental carbon,
- c) secondary organic aerosols (SOA) from biogenic sources and anthropogenic sources.

An initial estimate of the particulate matter mass distribution in Europe is presented, based on separate estimates of the contributions from each of these three components. Comparison of modelled results with available measurements shows a general underestimation by the model results that is not easy to explain. The analysis has served to identify serious limitations in the availability of data and information at European level.

In particular, further efforts should be dedicated to:

- study secondary organic aerosol formation and the quantification of their concentrations in Europe,
- refine the estimation of primary emission of particulate matter in order to distinguish its chemical speciation, specially organic and elemental carbon,
- harmonise the methods for measuring PM₁₀ mass and analyse its chemical composition.

3.1 Short models description

An initial estimate of the total concentration of particulate matter in Europe has been calculated as the sum of secondary inorganic aerosols (SIA), primary particulate matter (PPM) and biogenic secondary organic aerosols (BSOA). The

calculations presented here have been carried out with three independent runs of different versions of the EMEP models.

Secondary inorganic aerosols (SIA), comprising sulphates, nitrates, and ammonium salts, have been calculated for 1998 with the EMEP Eulerian Acid Deposition model version. The model is described in detail in Berge and Jakobsen (1998) and Bartnicki et al. (1998). Major changes in the present version of the model and thorough validation of model performance against observations can be found in Olendrzyński (2000). The 1998 updated calculations presented here are based on verified 1998 meteorological fields (Lenschow and Tsyro, 2000) and official submissions by the Parties to the Convention on total emissions of precursor gases. The reported 1998 emission estimates of sulphur dioxide (SO₂) nitrogen oxides (NO_x) and ammonia (NH₃) can be found in Vestreng and Støren (2000).

The atmospheric concentrations of primary particulate matter (PPM) have been computed with a modified version of the EMEP Eulerian dispersion model. The EMEP Eulerian model version for PPM is a first step towards the development of an Eulerian aerosol model, flexible enough to allow for the description of different size ranges. At present only two types of particles are distinguished by the model: particles with aerodynamic diameters smaller than 2.5 µm (PM_{2.5} or fine particles) and particles with aerodynamic diameters between 2.5 and 10 µm (coarse particles). Air concentration of PM₁₀ (particles with aerodynamic diameters smaller than 10 µm) is then derived as the sum of fine and coarse aerosols mass. The model uses the same horizontal, vertical and temporal resolution as the Eulerian EMEP model. The description of advection and diffusion, and the treatment of emissions are common with the Eulerian Acid Deposition model version. The main changes affect the description of chemical transformation and wet and dry deposition.

At present, the model is used only for modelling the atmospheric dispersion of anthropogenic primary particles (PPM) that are considered to be chemically inert. Therefore, the chemical transformation routine has been neglected. The dry deposition parameterisation has been modified to allow for a distinction of removal processes according to particle size and land use type. The wet deposition parameterisation has also been modified to allow for different in-cloud and sub-cloud scavenging parameters depending on particle size. The Eulerian PPM model sensitivity to the choice of dry and wet deposition parameterisation is documented and analysed in Tsyro and Erdman (2000).

Model results for PPM have been calculated based on 1998 meteorological data and emission data from 1990. Primary PM_{2.5} and PM₁₀ emission data from the 1990 TNO emission inventory by Berdowski et al. (1998) have been disaggregated to the EMEP 50 km grid according to SNAP1 sectors to be used in the model.

The Lagrangian Photooxidant model with 150 km horizontal resolution has been employed to derive 3-year (1993, 1995 and 1996) averaged air concentrations of biogenic secondary organic aerosols (BSOA). Andersson-Sköld and Simpson (2000) describe how the Lagrangian model (Simpson, 1992, 1993, 1995) has been adapted to model the transport and deposition of primary organic aerosol from

anthropogenic sources, and secondary organic aerosol formation resulting from terpene emissions. In the same work, the biogenic contribution to SOA was found to be much greater than the anthropogenic SOA formed from anthropogenic (aromatic) VOC, at least in the Nordic countries. Further studies are however required to see if this finding holds for other parts of Europe.

More details of the chemical mechanism applied to describe BSOA formation and discussion on the model experimentations can be found in Andersson-Sköld and Simpson (2000). Following the conclusions from Andersson-Sköld and Simpson (2000), the chemical mechanism selected here to estimate BSOA has been derived from the work of Kamens et al. (1999). This method shows considerable success in simulating smog-chamber experiments over a wide range of conditions and seems to form a reasonable basis for extrapolate the physical/chemical mechanism to very different conditions. However, it should be pointed out that these BSOA estimates are only preliminary and subject to rather large uncertainties.

In Europe as a whole, biogenic emissions are estimated at more than 50% of anthropogenic NMVOC emissions (Guenther et al., 1995, Simpson et al., 1999). In the boreal forest regions of Scandinavia and northern Russia, emissions from biogenic sources exceed anthropogenic emissions (Isidorov, 1992, Simpson et al., 1999). Of the many hundreds of species known to be emitted from vegetation, it is thought to be the mono and sesqui-terpenes, which contribute most to aerosol formation. The chemical methodology used here concentrates on alpha-pinene, since this species and its products are mechanistically the best understood, and since alpha-pinene is thought to be the dominant emitted species in the boreal forests (Janson, 1993; Rinne et al., 2000; Lindfors et al., 2000).

For this calculation of biogenic secondary organic aerosol concentrations, emissions of SO₂, NO_x, NMVOC and CO are taken from Mylona (1999), terpene emissions are derived from Simpson et al. (1999) and primary organic aerosols are derived from the TNO 1990 emission inventory (Berdowski et al., 1998). The resulting concentrations have been interpolated from EMEP 150 km to 50 km grid for consistency in the comparison with the other components.

3.2 Calculated concentrations of particulate matter in Europe

The total concentrations of particulate matter in Europe calculated as the sum of primary particulate matter (PPM), secondary inorganic aerosols (SIA) and biogenic secondary organic aerosols (BSOA) are presented in Figure 3.1.

The annual average of total PM concentrations is estimated to exceed 20 µg/m³ in parts of central Europe, Ukraine and Russian Federation, with maximum values above 30 µg/m³. In Belgium, The Netherlands and northern Italy maximum values are related mainly to high concentrations of SIA. In Poland, Ukraine and central Russian Federation maximum values are mostly due to the contribution of primary particulate matter (PPM).

SIA+PPM+BSOA

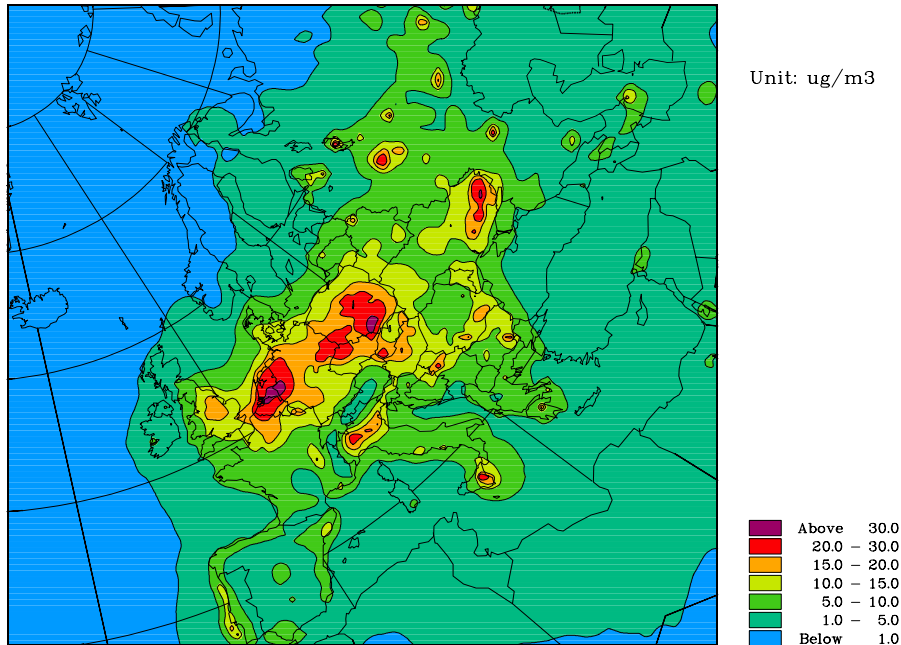

Figure 3.1: Annual mean concentrations of total particulate matter.

Figure 3.2 shows the estimated yearly averaged concentrations and relative contributions to total PM mass by the three considered aerosol components.

Secondary inorganic aerosols (SIA) are found to be the most important contributors to total aerosol mass (Figure 3.2(a)). The contribution from sulphates, nitrates and ammonium to the total PM concentrations varies from 30-50 % in eastern Europe to 50-70 % in western and northern Europe.

The second largest contributor to total PM mass is primary particulate matter (Figure 3.2(b)). The contribution from PPM varies from 50-70 % in eastern Europe and Russian Federation, to 30-50 % in central, southern and northern Europe. The contribution from primary PM decreases below 30 % in remote areas.

Biogenic secondary organic aerosols (Figure 3.2(c)) appear to be most important in northern Europe and the Russian Federation, where BSOA contribute with up to 30 % to the total aerosol mass. This is not surprising because in the boreal forest regions emissions from biogenic sources are dominant. In Turkey the concentrations of BSOA represent about 10-25% of the total calculated aerosol mass. Otherwise, the contribution from biogenic SOA is estimated to be below 5% of the total mass.

The BSOA concentrations are found to vary greatly across the different locations, and show also significant seasonal variations. Maximum BSOA concentrations are found for the month of July. The calculations by Andersson-Sköld and Simpson (2000) suggested that biogenic SOA formation was greater than anthropogenic SOA, at least for the Nordic countries. Therefore, the contribution for anthropogenic secondary organic aerosols has not been included here.

(a)

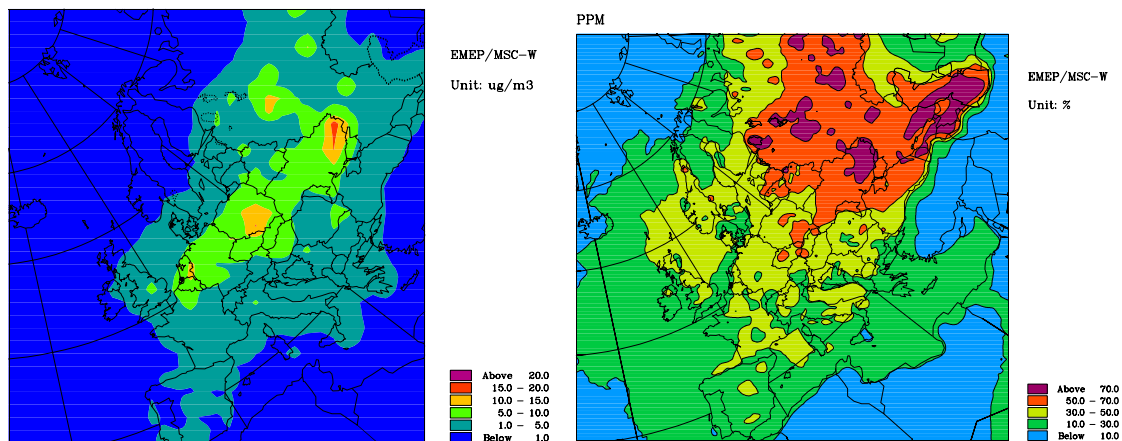

(b)

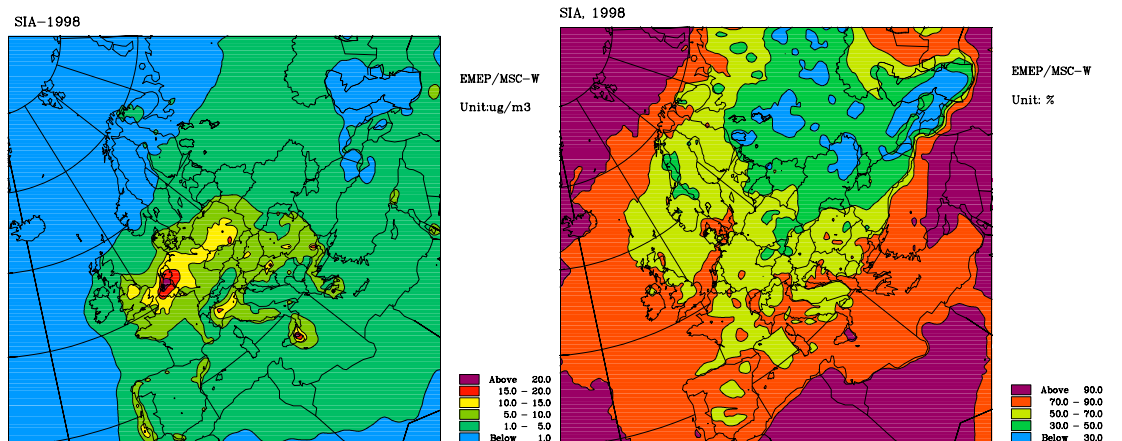

(c)

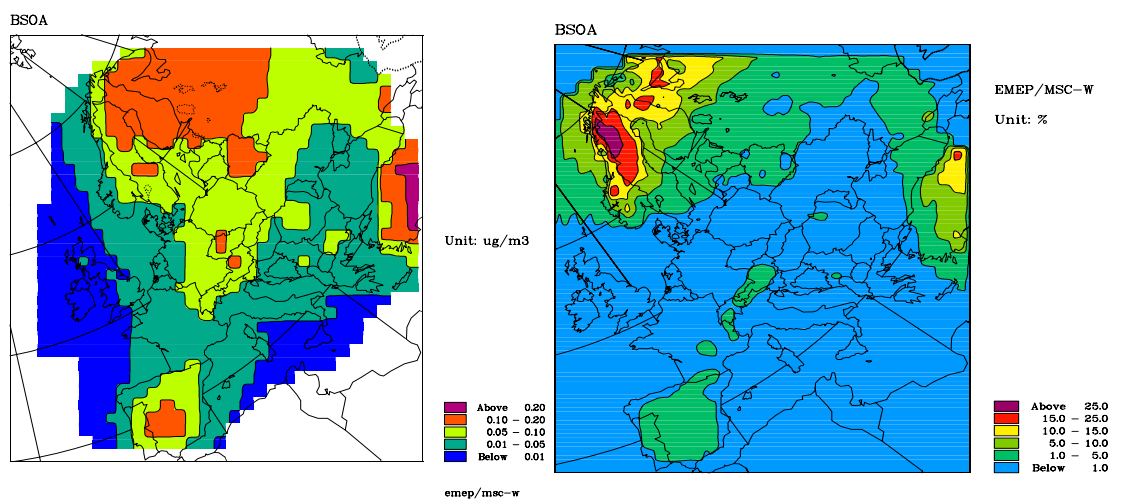

Figure 3.2: Annual mean concentrations and relative contributions to the total PM concentrations from: (a) primary PM₁₀, (b) secondary inorganic aerosols, and (c) biogenic secondary organic aerosols.

3.3 Comparison with observations

Model calculated air concentrations of particulate matter (PM_{10}) have been compared with observations at selected sites. In Figure 3.3 monthly averaged observations of suspended particulate matter (SPM) for 1998 at four EMEP sites are compared with modelled PM_{10} values. The modelled values of PM_{10} include primary particulate matter, secondary inorganic and biogenic secondary organic aerosols (not plotted here because of the very low contributions). The observed values have been compiled using different methods (ref. Chapter 2.1.1.) and may not be directly comparable.

In general, the calculated and observed air concentrations compare reasonably well. The largest discrepancies in Figure 3.3 are found at ES1. This is possibly attributed to the fact that the PM concentrations in Spain are measured as total suspended particles (TSP), which also include particles larger than $10\ \mu m$. The fraction of these particles is expected to be high at Spanish sites due to the re-suspension of large particles under dry conditions.

The relatively consistent underestimation by modelled results may not be related to a single reason. This underestimation of PM mass could be related to underestimation of each of the considered components, namely SIA, PPM and SOA. The neglecting, in the present computations, of some other contributors to the ambient aerosol mass (e.g. sea salt, natural mineral dust and crustal material, background aerosols) is another reason for relatively low modelled PM_{10} concentrations. The uncertainties in calculated SIA, PPM and BSOA are discussed below.

Figure 3.4 compares mass balance for the calculated PM_{10} with observations of the chemical composition of aerosol under different campaigns. However, it is difficult to extract definitive conclusions on the validity of the chemical composition of the modelled data from these figures because:

- a) different methods have been used at different stations to determine total PM mass, and
- b) most of measured PM concentrations and chemical compositions are typical for the particular emission episodes during the measurement campaigns, while model results give yearly average PM_{10} concentrations.

In principle, the underestimation of total PM mass values could be related to the underestimation of SIA, namely, sulphate, nitrates and ammonium by the EMEP Acid Deposition Model version as documented in Olendrzyński (2000). In Figure 3.4, the relative contributions of SO_4 and NH_4 to total aerosol mass compare rather well with observations, while their mass concentration is still somewhat underpredicted. However, the model is found to overestimate the relative fraction of NO_3 in several cases. The reason may be related to sampling artifacts, particularly evaporation of ammonium nitrate and other volatile constituents from the filters while sampling. This is specially the case for Aspvreten that uses TEOM methods for determination of SPM. The seeming disagreement with the conclusions from Olendrzyński (2000) that the model tends to underestimate NO_3 can be explained that in that work the total NO_3 mass, namely, the sum of gaseous nitric acid and particulate nitrate, was verified.

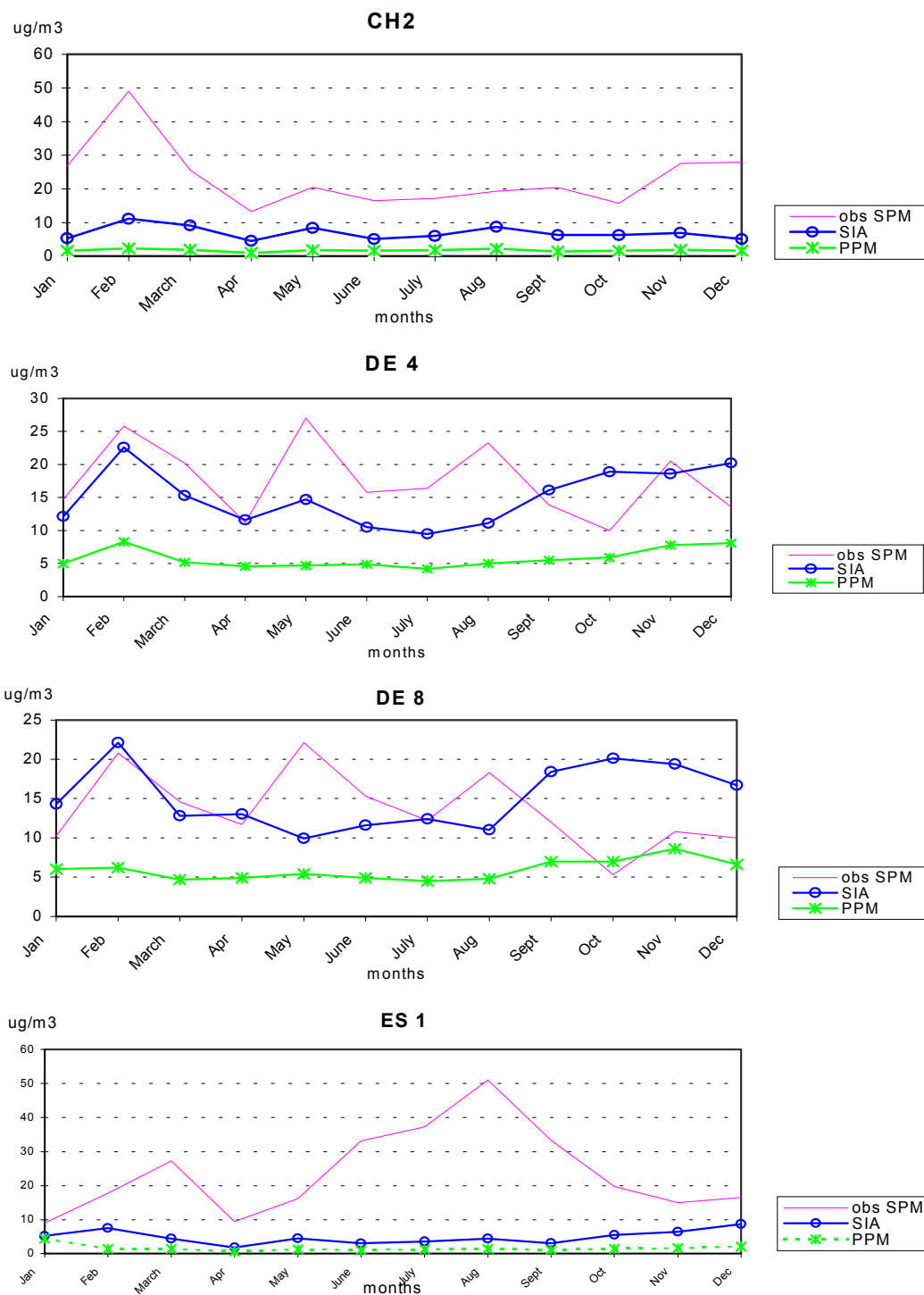
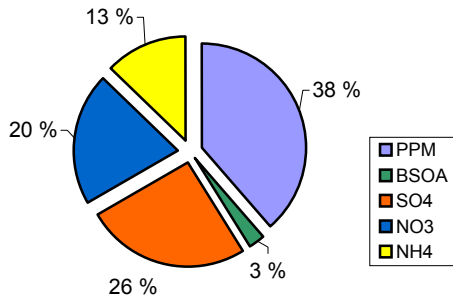

Figure 3.3: Comparison of modelled concentrations of PM_{10} (sum of primary, secondary inorganic and biogenic secondary organic aerosols) with measured in 1998 suspended particulate matter concentrations at EMEP station: (a) CH2 (Payerne, Switzerland), (b) DE4 (Deuselbach, Germany), (c) DE8 (Schmücke, Germany), (d) ES1 (Toledo, Spain).

EMEP modelled PM₁₀
1999)

Measurements PM_{1,5} (Zappoli et al.,

Aspvreten, Sweden (background)



1998 yearly aver. PM conc. = 3.1 µg/m³

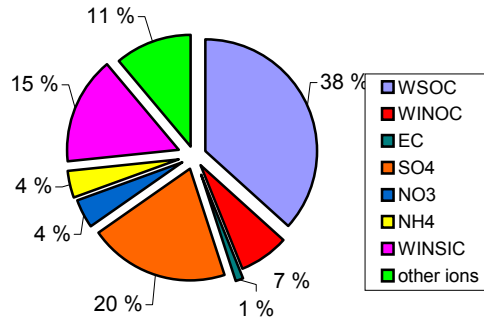

June/July-1996 5-day aver. conc. = 5.9 µg/m³

K-pusztá, Hungary (rural)

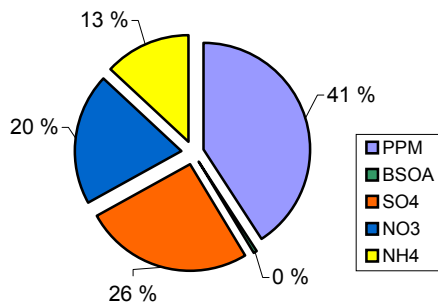

1998 yearly aver. PM conc. = 15.9 µg/m³

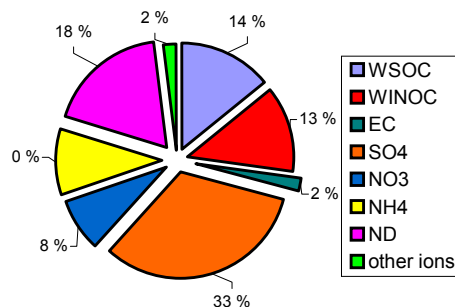

July/Aug-1996 5-day aver. conc. = 24.0 µg/m³

San Pietro Capofiume, Italy (polluted)

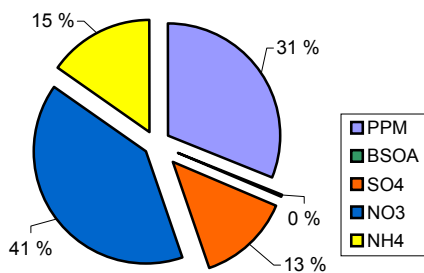

1998 yearly aver. PM conc. = 16.9 µg/m³

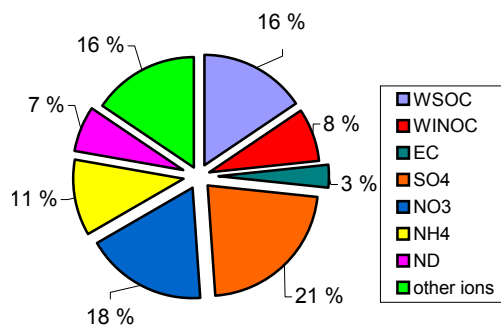

Sept/Oct-1996 6-day aver. conc. = 38.0 µg/m³

Figure 3.4: Comparison of mass balances for the modelled 1998 annual mean PM₁₀ and the measured during 06-10/1996 campaign (Zappoli et al., 1999).

WINSOC=water insoluble organic compounds, WINSIC=water insoluble inorganic compounds, WSOC=water soluble organic compounds, ND=not determined, other ions=Na⁺, K⁺, Ca²⁺, Mg²⁺, Cl⁻).

EMEP modelled PM₁₀

Helsinki (rural)

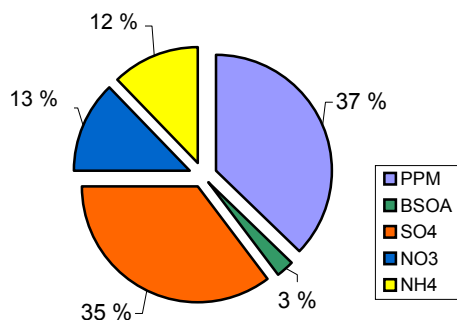

1998 yearly aver. PM₁₀ conc. = 3.5 µg/m³

Measurements PM

(Pakkanen et al., 1999)

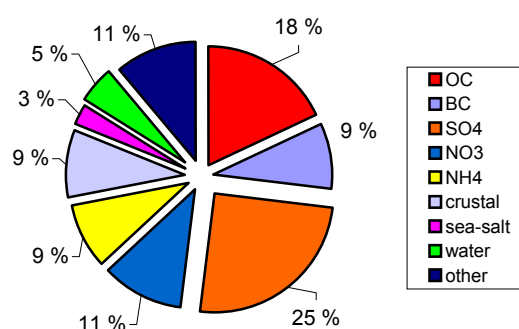

Apr-96/Jun-97 aver. PM_{2.5} conc. = 7.8 µg/m³

Voerde, Germany (rural)

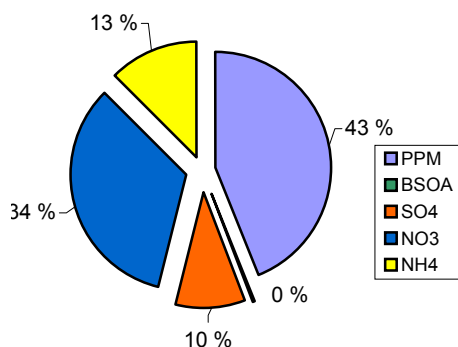

1998 yearly aver. PM₁₀ conc. = 29.4 µg/m³

(Kuhlbusch et al., 1999)

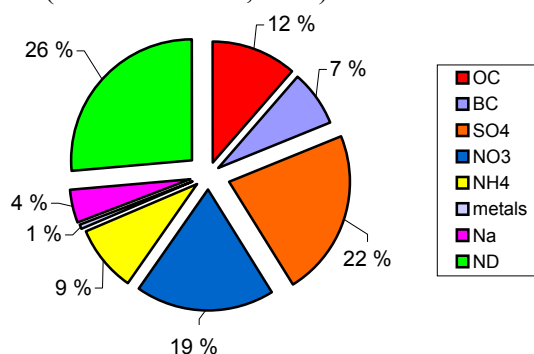

Sep/Oct-97, Jul/Aug-98 PM₁₀ = 10-143 µg/m³

Oberhausen, Germany (urban background) (Kuhlbusch et al., 1999)

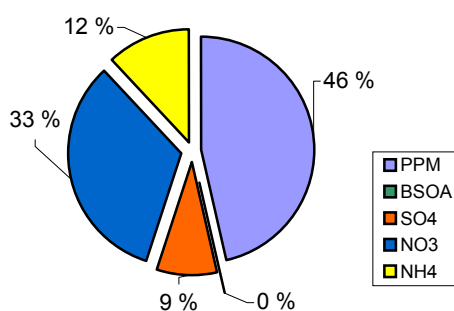

1998 yearly aver. PM₁₀ conc. = 36.0 µg/m³

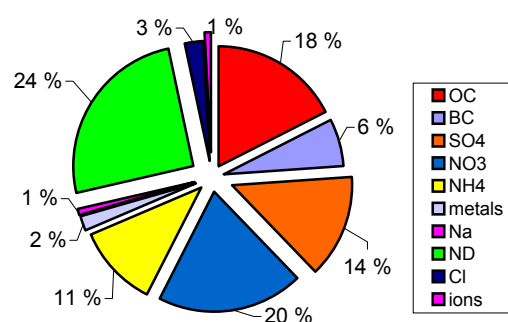

Feb/March-98 PM₁₀ conc. = 23-97 µg/m³

Figure 3.4 (cont.): Chemical composition of aerosols: modelled 1998 annual mean PM₁₀ and measured in different campaigns.

WINSOC=water insoluble organic compounds, WINSIC=water insoluble inorganic compounds, WSOC=water soluble organic compounds, ND=not determined, other ions=Na⁺, K⁺, Ca²⁺, Mg²⁺, Cl⁻).

The reason for the differences between modelled and observed values in Helsinki station is that some aerosol components, like crustal dust and sea salt, have not been included in the present calculations.

Unfortunately, Figure 3.4 does not provide sufficient information to verify the individual contributions of elemental carbon (EC), primary and secondary OC. However, if we assume that the computed (PPM+BSOA) fraction approximately corresponds to the measured (OC+EC+metals) fraction, their combined contribution to the total aerosol mass compares rather reasonably.

Thus, Figure 3.4 gives a certain insight on how realistic the model predicted chemical composition of particulates is compared to the measured one. However, because of the reasons pointed out above, i.e. differences in the measurements techniques, averaging periods and aerosol components considered, the analysis performed here remains inconclusive with respect to the validity of the chemical composition of the modelled particulates.

3.4 Uncertainties in BSOA calculations

As recognised above, the formation of biogenic secondary aerosols (BSOA) is the most uncertain component in our estimates and it appears to be underestimated in the present calculations.

Ackermann et al. (1999) report that both anthropogenic and biogenic secondary organic aerosols can contribute significantly to $PM_{2.5}$, with modelled concentrations of up to $10 \mu\text{g}/\text{m}^3$ for an episode in July 1994. BSOA concentrations as high as $10 \mu\text{g}/\text{m}^3$ have also been reported for an episode by Derwent et al. (1999). These results are seemingly in disagreement with the EMEP calculations of SOA. However, several reasons causing the differences can be pointed out.

Firstly, Ackermann et al. (1999) used the aerosol formation scheme of Pandis et al. (1992), which is probably inferior to the more up-to-date gas-particle (G/P) methodology tested in Andersson-Sköld and Simpson (2000) and based upon the formulations of Odum et al. (1996). The Pandis-type approach probably gives an upper limit to aerosol formation, whereas the Odum-type approaches account for the fact that a large fraction of the semi-volatile organic compounds remain in the gas-phase for ambient concentrations.

Secondly, we present here monthly averages from the EMEP model, whereas Ackermann et al. (1999) looked at an episode, which was presumably chosen because of high concentrations. For comparison the maximum value found for July 1996 with the EMEP model was $7 \mu\text{g}/\text{m}^3$, occurring in southern Spain. Of course, all of these results are very preliminary and can be expected to change as knowledge of SOA formation increases. With current methods it would seem hard to predict SOA formation to better than a factor of 2, and greater uncertainties are quite likely.

In any case, the fraction of biogenic secondary organic aerosol in the total aerosol mass is believed to be on average relatively small, except for photochemical episodes. Therefore, the modelled total aerosol mass is not expected to be greatly influenced by the inaccuracies in BSOA concentrations. Further research is also

needed to determine the influence of anthropogenic SOA in regions other than Northern Europe.

3.5 The influence of emission changes in primary PM

An additional source of uncertainty in the total aerosol air concentration presented in this chapter is that emissions from different years have been used to estimate concentrations of different aerosol components. SIA have been calculated with 1998 emissions. Primary particulate matter emissions for 1990 compiled by TNO have been used to calculate PPM. BSOA air concentrations have been found using TNO emissions for 1990, and meteorology from 1993, 1995 and 1996. The small inter-annual variation found in the BSOA results suggests that meteorologically these results may be representative for 1998, but of course emissions may have changed substantially. Therefore, an attempt has been made to evaluate how representative are TNOs 1990 PPM emissions for the end of the 1990s. Furthermore, a test on sensitivity of the model calculated $PM_{2.5}$ and PM_{10} air concentration levels to possible changes in emissions of primary particulates from 1990 to 1998 was needed.

Emission inventories for primary PM are rather uncertain. Berdowski and Visschedijk (1999) carried out a verification of the 1990 TNO emission estimates with PM_{10} measurements in the Netherlands and concluded that the 1990 emissions were probably underestimated. This could be due to a number of sources not covered by this inventory (e.g. non-anthropogenic sources, incomplete re-suspension). They estimated an uncertainty in emissions for total Europe (excluding the Russian Federation) between 10-20 %, and likely higher for the former Soviet Union.

Available monitoring data on PM_{10} concentrations is insufficient to draw reliable conclusions about emission trends. However, a general decrease is registered in measured ambient concentrations of TSP and BC (EEA, 2000; Rembges et al., 1999, see also Figures 3.5 and 3.6 in this report). Berdowski et al. (1998) estimated a slight decrease in the total European PPM emissions between 1990 and 1993. This was mainly due to economic developments and changes in the type of fuel used for residential combustion in some countries. However, not all countries have decreased their PPM emissions in this period. Norway, for example has reported an increase in particle emission from 23 Ktonnes in 1990 to 25 Ktonnes in 1998 (Vestreng, pers.comm.).

Air pollution control techniques designed to reduce gas emissions often bring about a decrease in primary particulate emission. Therefore, reduction in primary PM_{10} emissions can be achieved as a consequence of the implementation of different Protocols under the Convention on Long-Range Transboundary Air Pollution (CLRTAP). The Second Sulphur Protocol is believed to be of relevance to emissions of primary PM, as its implementation will give side-benefits for PM_{10} . Since many heavy metals (HMs) are primarily particle-bound, the HMs Protocol aims at setting limit values for dust from stack emissions of various industrial processes and large combustion plants. Furthermore, the protocol on persistent organic pollutants (POPs) is also expected to have positive side effects for the reduction of primary PM_{10} emissions.

Berdowski and Visschedijk (1999) presented preliminary projections for primary PM_{10} emissions for year 2010. Those were made according to a number of scenario options, based on available economic and demographic components and on the analysis of the influence of environmental policy measures, such as the CLRTAP Second Sulphur Protocol and EU-regulations on particulates from stationary and mobile sources (see also WHO, 1999). In this report, the projections by Berdowski and Visschedijk have been used to make a rough approximation for PPM emissions in 1998 based on the TNO 1990 emissions of primary PM_{10} and $PM_{2.5}$.

According to the Business As Usual (BAU) scenario (Berdowski and Visschedijk, 1999), a slight or no increase in PM_{10} emissions is expected between 1990 and 2010 (increase in transport emissions due to growth in this sector will overcome the decrease due to changes in fuel type in emissions from stationary combustion). Based on BAU projection, the following changes in the 1990s in PM_{10} and $PM_{2.5}$ emissions have been assumed: 10% reduction from stationary combustion (power generation and industrial combustion) and 30% increase from traffic sources. In this case, the total European PM emissions remains practically unchanged, but national emissions in individual countries may increase or decrease depending on the dominating emission sectors.

The resulting PM_{10} concentrations (Figure 3.5) were estimated to decrease by about 1–5% in Poland, Romania, Yugoslavia, Bosnia and Herzegovina, Ukraine, Byelorussia, and parts of north-western Russia, where PM emissions are predominantly from the power generation sector. In many other regions, an increase in PM_{10} concentrations is found as a combined result of the decrease in emissions from industrial combustion and the increase of emissions from transport sector. Only slight increase (below 5%) due to prevailing industrial combustion sources is estimated for rest of eastern Europe and Russia. While in western Europe and England as large as 5 to 10 % and more increase in PM concentrations are calculated, as transport makes a significant PM emissions source in these areas.

Baseline, or Policies In Place and Pipeline (PIPP) scenario predicts about 30% emission decrease in 2010 compared to 1990 (Berdowski and Visschedijk, 1999). Main reasons are emission abatement in stationary combustion (due to among others the 2nd Sulphur Protocol) and more stringent emission limit values for transport vehicles. Reductions are expected to be largest in central and eastern Europe. Based on these estimates, we have assumed for our sensitivity tests a reduction in the emissions from stationary combustion sources of 30% and unchanged emission from transport sector. This assumption results in the decrease of the total PPM emissions by approximately 16%.

Application of PIPP scenario gives in 1998 an overall fall in PM_{10} concentrations level (Figure 3.6), with largest decrease of 15–20% related to the emission reduction from power generation sector. PM_{10} concentrations decrease between 10 to 15% in the eastern Europe and Russia is estimated due to the emission reduction from industrial combustion processes. In the rest of Europe, air concentrations of primary PM_{10} are expected to fall by 1–10%.

Reduction in PPM10, 1998 (BAU)

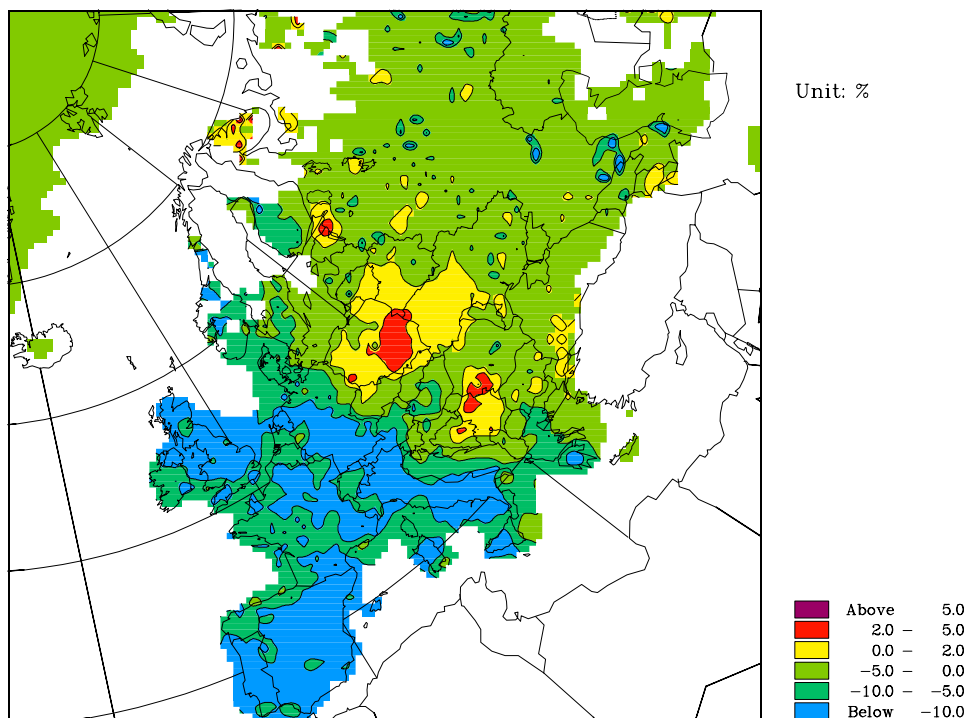
Figure 3.5: Reduction in PM_{10} air concentrations in 1998 (BAU scenario).

Reduction in PPM10 (PIPP)

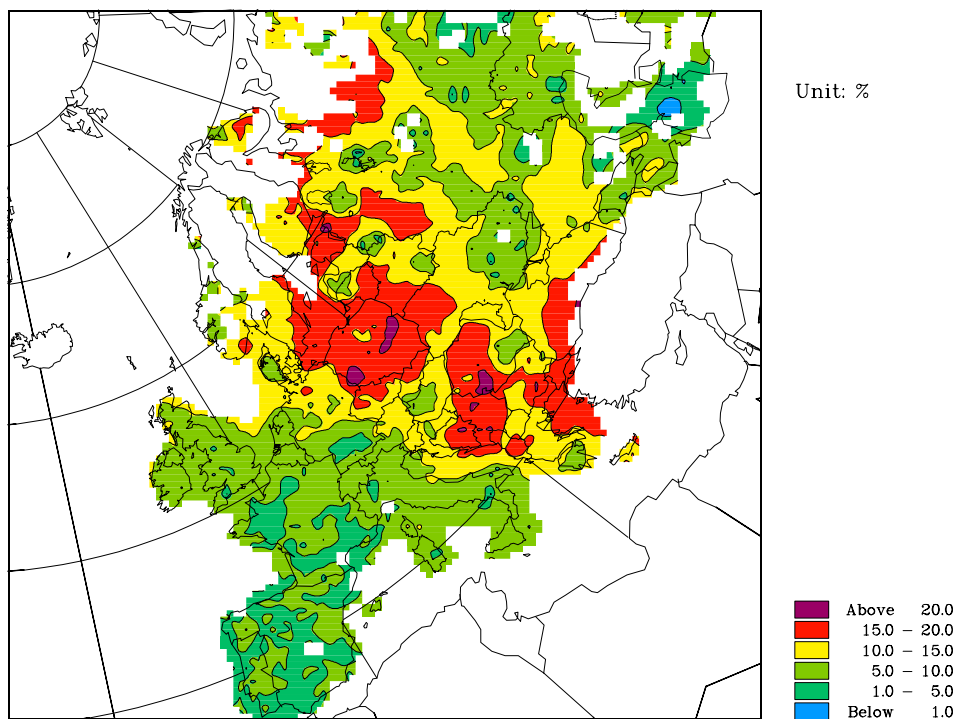
Figure 3.6: Reduction in PM_{10} air concentrations in 1998 (PIPP scenario).

Thus, the feasible changes during the 1990s in the total PPM emissions are expected to lie within the emissions uncertainties. Therefore, the PM_{10} and $PM_{2.5}$ emissions for 1990 can be considered as an acceptable estimate of PPM emissions for our assessment of aerosols total air concentrations. However, the geographical distribution of these changes depends on the sectoral distribution of PM emissions, so that in many areas the resultant changes in PM_{10} air concentrations are found to be rather small. Therefore, the calculated total aerosol mass in air is believed to be a rather good estimate of PM_{10} concentration in 1998.

3.6 Recommendations for further model development

EMEP/MSC-W aims at the development of a unified Eulerian model that can provide a modular description of the atmospheric dispersion of acidifying and eutrophying compounds, ground level ozone and atmospheric particles. A common framework formulation with shared subroutines is necessary to secure a flexible integration of the inter-related environmental problems.

The use of independent dispersion models presented in this chapter is appropriate for a first rough estimate of the particulate matter air concentrations but it will not be able to provide adequate description of aerosol size and number distribution. However, the main results and conclusions for total PM mass presented here are not expected to change drastically with the integration of aerosol dynamic modelling.

Experiments with the Modal Aerosol Dynamics model for Europe (MADE) by Ackermann et al. (1998) have shown that the introduction of nucleation process was important for number concentration. Total surface was only influenced significantly during the nucleation event, whereas total volume is not significantly influenced at all. Coagulation is a mass-conserving process. An indirect influence of coagulation on aerosol mass is introduced by size-dependent dry deposition, since coagulation changes the size of particles. However, as it was discussed in Tsyro and Erdman (2000), even rather large variation in dry deposition velocity caused comparatively moderate changes in aerosol mass concentration. The calculations performed with MADE also showed that the coagulation did not lead to a significant change of aerosol mass. Therefore, coagulation could be neglected in model calculations if only the aerosol mass has to be predicted. However, coagulation being a major loss process for small particle number concentration, controls to a large degree number concentration and aerosol surface area in the Aitken mode (and thus the total values). Condensation of gaseous species onto particles results in the particles growth and mass increase. It does not influence the particles number directly, but through the size-dependent processes such as coagulation and dry deposition.

Submicron particles are believed to be of a particular relevance in relation to adverse health effect. The contribution of these particles, especially ultra-fine ones, to the total aerosol mass is insignificant, and they are characterized preferably by number concentrations. Computation results for secondary inorganic aerosols with the Modal Aerosol Dynamics model for Europe (Ackermann et al., 1998) showed that after two-day transport the mass concentration field looked rather different from the number distribution. The maximum number concentrations in the Aitken mode were about an order of magnitude higher than in the accumulation mode. The spatial distribution of the number concentration in the

Aitken mode is clearly dominated by the areas of emissions indicating a freshly nucleated aerosol and shows strong horizontal gradients. For the accumulation mode, the maximum number concentrations were found in the aged aerosol plume.

Based on the discussion above, it can be anticipated that introduction of aerosol size distribution would not bring about a significant change in the total aerosol mass. However, there are still large uncertainties which characteristics of atmospheric aerosol are responsible for the human health damage, and whether it the particles number, surface area or chemical composition is more relevant in relation to the adverse health effects. Furthermore, certain aerosol properties may determine particles transport and removal from the atmosphere. For instance, aerosol size distribution effects their dry and wet deposition; particles chemical composition determines their hygroscopic properties and thus, wet scavenging. As it was already indicated, aerosol dynamics processes can greatly modify the aerosol size distribution.

In order to give an adequate description to the aerosol atmospheric transport, an aerosol dynamics module, allowing for nucleation, condensation and coagulation of atmospheric particles, is under presently under implementation in the EMEP Eulerian transport model.

The EMEP Eulerian Aerosol model will account for seven chemical aerosol components, i.e. sulphate, nitrate, ammonium, elemental carbon, organic aerosols, mineral dust and sea salt, which are assumed to be internally mixed, so that all particles in the same size mode have the same chemical composition. The size distribution of atmospheric particles is described by four modes: nucleation ($d_p < 0.02 \mu\text{m}$), Aitken ($0.02 < d_p < 0.1 \mu\text{m}$), accumulation ($0.1 < d_p < 2.5 \mu\text{m}$), and coarse ($d_p < 10.0 \mu\text{m}$). That makes up altogether 32 number and mass concentrations. Concentrations of $\text{PM}_{2.5}$ and PM_{10} as referred in European quality standards can be easily derived.

The monodisperse model approach developed of the University of Helsinki was selected to include aerosol dynamics in the Eulerian model. The main advantage of the monodisperse particles description with respect to the long-range transport modelling is a limitation of prognostic equation to two per mode, for particles mass and number concentration. Comparison of results from the monodisperse model (MULTIMONO), which is a result of collaboration between the University of Helsinki and MSC-W, with more sophisticated sectional aerosol models showed that MULTIMONO manages to describe the evolution of aerosol population at regional level with appropriate accuracy (Pirjola and Kulmala, 2000; Pirjola, 1998).

In the first step, the MULTIMONO (henceforth called MM32-TWOSTEP) model has been tested with a dedicated box-model to examine/experiment whether the two-step time integration scheme used in the EMEP Eulerian model could be applied for calculating the aerosol dynamics processes. A number of tests with varying input parameters and conditions were performed and results were compared with the original model version (referred to as MM32-NAG) of the University of Helsinki, which is solved by NAG-library FORTRAN routine. Only two components, SO_4 and OC (organic carbon), were considered this time, as well

as mass of aerosol bound liquid water parameterised using an approach by Binkowski and Shankar (1995). Processes of binary ($\text{H}_2\text{SO}_4 + \text{H}_2\text{O}$) and ternary ($\text{H}_2\text{SO}_4 + \text{NH}_3 + \text{H}_2\text{O}$) nucleation, condensation and coagulation have been calculated for the initial number concentration varying from 10^3 to 10^7 $1/\text{cm}^3$ and gaseous H_2SO_4 and VOC concentrations from zero (no condensation) to 10^{10} molec/m^3 . The comparison showed that MM-TWOSTEP was able for most of typical ambient conditions to reproduce 7-day calculations by the MM-NAG model. Testing of the monodisperse module will continue in order to complete the implementation of aerosol dynamics module in the EMEP Eulerian model and results of the progress will be provided in due time.

4. An assessment of particle emissions in Europe

by Mihalis Lazaridis, Jozef Pacyna and Arne Semb

The TNO Institute of Environmental Sciences, Energy Research and Process Innovation in the Netherlands has compiled an emission inventory for PM₁₀, PM_{2.5} and PM_{0.1} covering the whole of Europe for the years 1990 to 1993 (Berdowski et al., 1998). The 1990 data were spatially distributed on a 0.5°x 1°. This is the only available European-wide emission inventory of particulate emissions. This emission estimate has been prepared from available statistical information and emission factors and information about control technologies in the respective European countries. A sectoral split of the emissions is shown in Figure 4.1.

This inventory shows that the anthropogenic primary particle emissions are distributed over many different sectors and activities. There are marked differences between countries, both in terms of implementation of control technologies and in the relative importance of sectors.

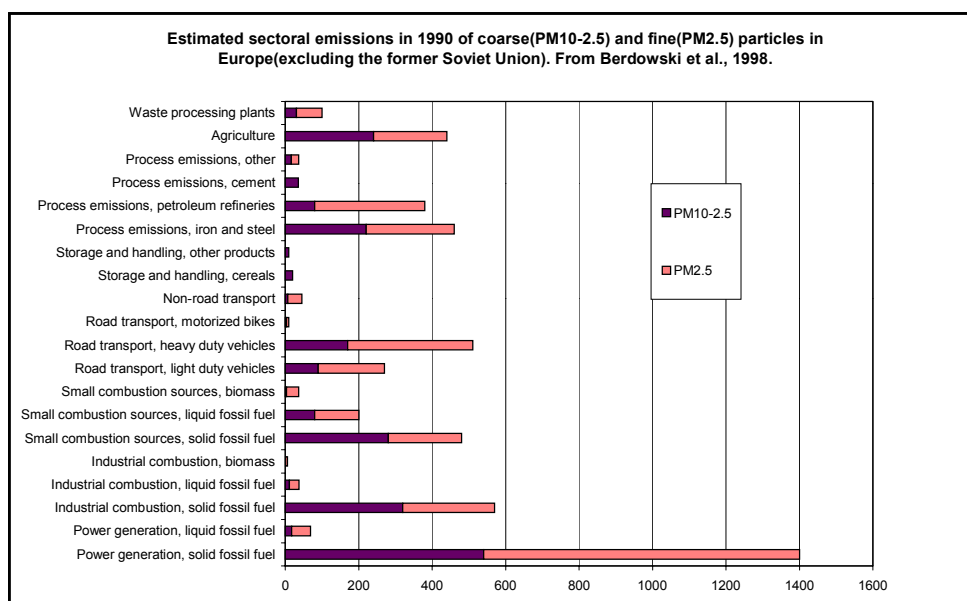

Figure 4.1: Sectoral distribution of particulate matter emissions in Europe (Berdowski et al., 1998).

For dispersion model calculations, this emission inventory needs to be updated to the present situation because of changes in the emissions during the last 10 years. This work will be undertaken by the TNO, in co-operation with the European Environment Agency, the Task Force on Emission Inventories and Projections, EMEP Centres, and the European Union. In this upgrading, attempts will also be made to include chemical speciation, which will be of use both in the modelling and in the interpretation of measurement results. The updated emission estimates are scheduled within the year 2000, countries will be asked to report comments and supplementary information. The results of the TNO inventory for PM₁₀ and PM_{2.5} will be taken as the basis for the 1995 (Berdowski et al., 1998) emission

inventory. Several improvements of the TNO inventory are expected, including the use of more complete and accurate emission factors, information on spatial distribution within the 50 km by 50 km grid, and information on chemical speciation.

In the next steps of the above mentioned EU initiative for the improvement of fine particle emission estimates in Europe it is expected that the interim emission data based on TNO emission inventory will be approved by the European countries. Finally, a baseline emission inventory for fine particles will be prepared for the reference years 2010 and 2020.

It is seen that the emissions of particulate matter occur from a number of different sources and processes. For the latter, as well as from solid fuel combustion in large point sources, emissions are critically dependent on the installed control equipment (cyclones, electrostatic precipitators, filters) and their operation. In other applications, emissions arise mainly from the incomplete combustion of fuels, resulting in a mixture of soot, or black carbon and other organic compounds with low volatility. In the case of diesel engines, which have been extensively studied, the ratio of black carbon to organic compounds in the emitted particles is typically 1:1 or 1:0.8. At the other extreme, particles from low-temperature combustion and pyrolysis of bio-fuels contain largely oxygenated organic compounds and relatively small amounts of black carbon particles. Again, however, emissions depend very much on the actual combustion conditions and the properties of the fuels used.

The TNO emission inventory has been compared with national emission inventories for particulate matter in some EMEP countries. In general, these comparisons have shown generally good agreements with respect to total emissions, and for the transport sector, but substantial differences for individual sectors where national conditions are different from the assumptions used in the TNO inventory. There may also have been cases where national authorities have overlooked some emission sources.

The chemical composition of the particulate emissions is less well known than the chemical composition of the particles in ambient air. As mentioned above, inorganic minerals are mainly emitted from processes, particularly from cement and iron and steel industry, and as fly ash from coal combustion. Organic compounds and soot are mainly emitted from small combustion sources, mobile sources and from processes associated with petroleum extraction and refining. The ratio of organic to elementary carbon in these emissions is rather variable, from less than 1 in the case of emissions from diesel engines, up to 5–10 for low-calorific fuels such as lignite, peat and firewood.

In Figure 4.1 the relative contribution of $PM_{10}/PM_{2.5}$ to the emissions of different categories is presented. Clearly, much more information may be obtained from the countries, which in some cases have detailed knowledge about the emissions from process industries and other large sources, as well as information about the properties of fuel and the typical combustion conditions and technologies applied in the residential sector. Emissions from solid fuel also vary with the fuel's content of volatile materials, coals burning with a smoky flame are known as

”steam coals” because they are particularly useful as boiler fuels. Firewood with a large content of resinous material may also burn with very smoky flames.

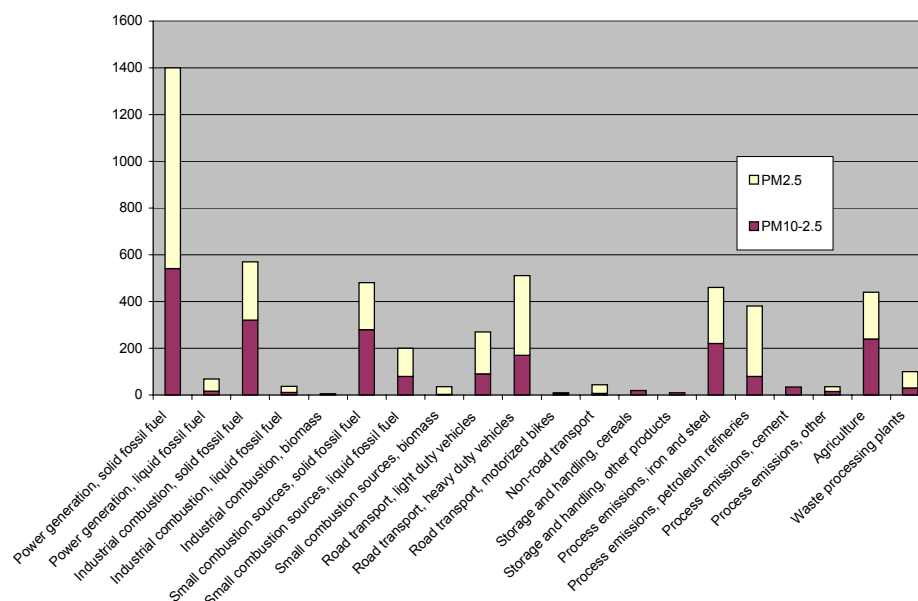

Figure 4.2: Relative contribution of $PM_{10}/PM_{2.5}$ to the emissions of different categories from the TNO inventory.

The anthropogenic emissions as discussed earlier can be divided in three main areas:

1. Incomplete combustion, formation of soot and associated organic compounds (COC). (Including small-scale residential combustion, both solid and liquid fuels, and internal-combustion engines.)
2. Fly ash and particles from the fuel's content of inorganic mineral matter. The efficiency of control equipment.
3. Industrial processes.

Particles can be generated from natural and anthropogenic sources. In general, it is estimated that the annual total amount of particles from these sources is about 3000 million tonnes and 400 million tonnes, respectively (Hinds, 1999). Particles from natural sources are overwhelmingly coarse particles, from wind erosion, sea-spray formation and similar processes. Anthropogenic emissions on the other hand, contribute about 60 % to the total fine particle mass in the atmosphere. Behind these estimates lie large uncertainties in terms of source assessment, speciation, and characterisation of the atmospheric particles, not to mention the different life times of particles. A rough estimate of their contribution to particulate aerosol mass on a global scale is given in Table 4.1.

Table 4.1: *Estimated contributions to the global atmospheric particulate mass (adapted from Hinds (1999)).*

	Annual emission or production, Tg/a	
	Range	Best estimate
Natural:		
Wind erosion	1000-3000	1500
Sea salt	1000-10 000	1300
Volcanoes	4-10 000	30
Biological primary particles	26-80	50
Forest fires	3-150	20
Inorganic secondary particles ¹	100-260	180
Organic secondary particles ²	40-200	60
Anthropogenic:		
Direct emissions	50-160	120
Inorganic secondary particles ¹	260-460	330
Organic secondary particles ³	5-25	10

¹ Oxidation of sulphur dioxide, reduced sulphur compounds and nitrogen dioxide, uptake of ammonia.

² Mainly photochemical formation of particulate matter from isoprene and monoterpenes.

³ Photochemical formation of particulate matter from anthropogenic emissions of VOCs.

These emission and formation figures are rather uncertain. It should also be taken into account that the residence times of particles from the respective sources are very variable. The difficulty in assessing the emissions of sea-salt particles from the sea surface, and of soil and desert dust from wind erosion, is partly due to the rapid sedimentation and deposition of these particles. Coarse particles have generally short residence times, typically of the order of few days. Fine particles, such as the inorganic and organic secondary particles, have atmospheric residence times of 1–2 weeks. Natural sources are also distributed over very large areas, whereas the more densely populated areas of Europe and North America comprise only 2–3% of the global area.

5. References

- Ackermann, I.J., Hass, H., Memmesheimer, M., Ebel, A., Binkowski, F.S. and Shankar, U. (1998) Modal aerosol dynamics model for Europe: Development and first applications. *Atmos. Environ.*, 32, 2981-2999.
- Ackermann, I.J., Hass, H., Schell, B. and Binkowski, F.S. (1999) Regional modelling of particulate matter with MADE. *Environ. Manage. Health*, 10/4, pp. 2-1 – 2-8.
- Allen, G., Sioutas, C., Koutrakis, P., Reiss, R., Lurmann, F.W. and Roberts, P.T. (1997) Evaluation of the TEOM method for measurement of ambient particulate mass in urban areas. *J. Air Waste Manage. Assoc.*, 47, 682-689.
- Amundsen, C.E., Hanssen, J.E., Semb, A. and Steinnes, E. (1992) Long-range transport of trace elements to southern Norway. *Atmos. Environ.*, 26A, 1309-1324.
- Andersson-Sköld, Y. and Simpson, D. (2000) Secondary organic aerosol formation in Northern Europe: a model study. Submitted to *J. Geophys. Res.*
- Andreae, M.O. and Crutzen, P.J. (1997) Atmospheric aerosols: biogeochemical sources and role in atmospheric chemistry. *Science*, 276, 1052-1058.
- Bartnicki, J., Olendrzynski, K., Jonson, J. E. and Unger, S. (1998) Description of the Eulerian acid deposition model. In: *Transboundary acidifying air pollution in Europe. MSC-W Status Report 1998*. Part 2. Oslo (EMEP/MS-CW Report 1/98).
- Berdowski, J.J.M. and Vesschedijk, A.J.H (1999) European PM₁₀ and PM_{2.5} emission inventory of anthropogenic sources. Oral presentation at WMO/EMEP Workshop on Fine Particles: Emission, Modelling and Measurements, Interlaken, Switzerland, 22-25 November 1999.
- Berdowski, J.J.M., Mulder, W., Veldt, C., Vesschedijk, A.J.H. and Zandved, P.Y.J. (1997) Particulate matter emissions (PM₁₀-PM_{2.5}-PM_{0.1}) in Europe in 1990 and 1993. Apeldoorn (TNO-MEP-R 96/472).
- Berdowski, J.J.M., Mulder, W., Veldt, C., Visschedijk, A.J.H. and Zandveld, P.Y.J. (1998) Particulate emissions (PM₁₀-PM_{2.5}-PM_{0.1}) in Europe in 1990 and 1993. Bilthoven, RIVM.
- Berge, E. and Jakobsen, H.A. (1998) A regional scale multi-layer model for the calculation of long-term transport and deposition of air pollution in Europe. *Tellus*, 50B, pp. 205-223
- Birch, M.E. and Cary, R.A. (1996) Elemental carbon-based method for monitoring occupational exposures to particulate diesel exhaust. *Aerosol Sci. Technol.*, 25, 221-241.

- Cachier, H., Bremond, M.-P. and Buat-Ménard, P. (1989) Determination of atmospheric soot carbon with a simple thermal method. *Tellus*, 41B, 379-390.
- CEN (1998) Air quality – Determination of the PM₁₀ fraction of suspended particulate matter – Reference method and field test procedure to demonstrate reference equivalence of measurement methods. European Committee for Standardization (European Standard EN 12341).
- Chow, J.C., Watson, J.G., Pritchett, L.C., Pierson, W.R., Frazier, C.A. and Purcell, R.G. (1993) The DRI thermal/optical reflectance carbon analysis system: description, evaluation and application in U.S. air quality studies. *Atmos. Environ.*, 27A, 1185-1201.
- Commission of the European Communities (1996) Ambient air pollution by particulate matter, Executive Summary.
- Commission of the European Communities (1997) Proposal for a council directive relating to limit values for sulphur dioxide, oxides of nitrogen, particulate matter and lead in ambient air. Luxembourg, Office for Official Publications of the European Communities. (Documents/Commission of the European Communities) (COM(97) 500 final) (CB-CO-97-525-EU-C).
- Eliassen, A. and Saltbones, J. (1983) Modelling of long range transport of sulphur over Europe: a two year model run and some model experiments. *Atmos. Environ.*, 17, 1457-1473.
- EMEP-WMO (1999) Workshop on Fine Particles - Emissions, Modelling and Measurements. Interlaken, Switzerland. Proceedings. Kjeller, Norwegian Institute for Air Research (in preparation).
- EMEP/CORINAIR (1996) Atmospheric emission inventory guidebook. Copenhagen, European Environment Agency.
- EPA (1996) Air quality criteria for particulate matter. Washington, Environmental Protection Agency (EPA 600/P-95-001).
- European Commission (1998) Ambient Air Pollution by Particulate Matter. Position Paper on Particles. Technical Working Group on Particles.
- Finlayson-Pitts, B.J. and Pitts, J.N. (1986) Atmospheric chemistry: fundamentals and experimental techniques. New York, Wiley.
- Guenther, A. et al. (1995) A global model of natural volatile organic compound emissions. *J. Geophys. Res.*, 100, 8873-8892.
- Harrison, R.M. and Yin, J. (2000) Particulate matter in the atmosphere: which particle properties are important for its effects on health? *Sci. Total Environ.*, 249, 85-101.

- Hedin, L.O., Granat, L., Likens, G.E., Buishand, T.A., Galloway, J.N., Butler, T.N. and Rodhe, H. (1994) Steep declines in atmospheric base cations in regions of Europe and North America. *Nature*, 367, 351-354.
- Heintzenberg, J. (1989) Fine particles in the global troposphere - a review. *Tellus*, 41B, 149-160.
- Heintzenberg, J., Müller, K., Birmili, W., Spindler, G. and Wiedensohler, A. (1998) Mass-related aerosol properties over the Leipzig basin. *J. Geophys. Res.*, 103, 13125-13135.
- Hinds, W.C. (1999) Aerosol technology. Properties, behavior, and measurement of airborne particles. New York, Wiley.
- Hutzincker, J.J., Hoffmann, R.S. and Cary, R.A. (1984) Aerosol sulfur episodes in St. Louis, Missouri. *Environ. Sci. Technol.*, 18, 962-967.
- Isidorov, V. (1992) Non-methane hydrocarbons in the atmosphere of boreal forests: composition, emission rates, estimation of regional emission and photocatalytic transformation. *Ecol. Bull.*, 42, 71-76.
- Janson, R., (1993) Monoterpene emissions from Scots pine and Norway spruce. *J. Geophys. Res.*, 98, 2839-2850.
- Kamens, R., Jang, M., Chien, C. and Leach, K. (1999) Aerosol formation from the reaction of alpha pinene and ozone using a gas-phase kinetics-aerosol partitioning model. *Environ. Sci. Tech.*, 33, 1430-1438.
- Kuhlbusch, T.A.J., John, A.C., Fissan, H., Schmidt, K.-G., Schmidt, F, Pfeffer, H.-U. and Gladtko, D. (1999) PM₁₀ and PM_{2.5} mass concentration, chemical composition, and size distribution measurements at three different sites in the Ruhr-area, Germany. *J. Aerosol Sci.*, 30, S45-S46.
- Lannefors, H., Hansson, H.-C. and Granat, L. (1983) Background aerosol composition in southern Sweden – Fourteen micro and macro constituents measured in seven particle size intervals at one site during one year. *Atmos. Environ.*, 17, 87-111.
- Lazaridis, M., Semb, A. and Hov, Ø. (1999) Long-range transport of aerosol particles. A literature review. Kjeller, Norwegian Institute for Air Research (EMEP/CCC-Report 8/99).
- Lazaridis, M., Semb, A., Larssen, S., Hjellbrekke, A.-G., Hov, Ø., Hanssen, J.E., Schaug, J., Tarrason, L., Tsyro, S. (2000) Status report with respect to measurements of particulate matter in EMEP. Kjeller, Norwegian Institute for Air Research (EMEP/CCC-Report 1/2000).
- Lenschow, H. S. and Tsyro, S. (2000) Meteorological input data for EMEP/MS-CW air pollution models. Oslo (EMEP/MS-CW Note 2/00).
- Lindfors, V., Laurila, T. and Hakola, H. (2000) Biogenic terpene emissions from Nordic forests. In: *Sensitivity studies of the effect of biogenic emissions on*

- ozone and aerosol formation, and implications on the benefits of the VOC and NO_x Protocols in Nordic areas, Part I*, NMR Project. Helsinki, Finnish Meteorological Institute.
- Liu, B.Y.H. and Pui, D.Y.H. (1981) Aerosol sampling inlets and inhalable particles. *Atmos. Environ.*, *15*, 589-600.
- Liousse, C., Cachier, H. and Jennings, S.G. (1993) Optical and thermal measurements of black carbon aerosol in different environments. *Atmos. Environ.*, *27A*, 1203-1211.
- Mylona, S. (1999) EMEP emission data: Status report 1999. Oslo, Norwegian Meteorological Institute (EMEP/MSC-W Note 1/99).
- Olendrzynski, K. (2000) Performance of EMEP Eulerian Acid Deposition Model for 1998. Oslo, Norwegian Meteorological Institute (EMEP/MSC-W Note 3/00).
- Olendrzynski, K. (1999) Operational EMEP Acid Deposition Model. Oslo, Norwegian Meteorological Institute (EMEP/MSC-W Note 4/99).
- Pakkanen, T.A., Hillamo, R.E., Keronen, P., Maenhaut, W., Ducastel, G. and Pacyna, J.M. (1996) Sources and physico-chemical characteristics of the atmospheric aerosol in Southern Norway. *Atmos. Environ.*, *30*, 1391-1405.
- Pakkenen, T., Ojanen, C. Hillamo, R., Aurela, M., Aarnio, P., Koskentalo, T. and Maenhaut, W. (1999) Mass balance of atmospheric fine particles in the Helsinki area. *J. Aerosol Sci.*, *30*, S275-S276.
- Pacyna, J.M., Semb, A. and Hanssen, J.E. (1984a) Emission and long range transport of trace elements in Europe. *Tellus*, *36B*, 163-178.
- Pacyna, J.M., Ottar, B., Hanssen, J.E. and Kemp, K. (1984b) The chemical composition of aerosols measured in Southern Scandinavia. Lillestrøm (NILU OR 66/84).
- Pandis, S.N., Harley, R.A., Cass, G.R. and Seinfeld, J.H. (1992) Secondary organic aerosol formation and transport. *Atmos. Environ.*, *26A*, 2269-2282.
- Pirjola, L. and Kulmala, M. (2000) Aerosol dynamical model MULTIMONO. Submitted to *Boreal Environ. Res.*
- Rembges, D., Brun, C. Bo, F. and Fantechi, G. (1999) Measurements of particles at the monitoring stations of the joint research centre, Ispra, 1988–1999. Oral presentation at WMO/EMEP Workshop on Fine Particles: *Emission, Modelling and Measurements*, held in Interlaken, Switzerland, 22-25 November 1999.
- Rinne, J., Hakola, H., Laurila, T. and Rannik, U. (2000) Canopy scale monoterpene emissions of Pinus sylverstris dominated forests. *Atmos. Environ.*, *34*, 1099-1107,.

- Schaug, J. and Uhse, K. (1997) EMEP-WMO Workshop on Strategies for Monitoring of Regional Air Pollution in relation to the need within EMEP, GAW and other international bodies, Lerum, Sweden, June 2-4, 1997. Kjeller, Norwegian Institute for Air Research (EMEP/CCC-Report 10/97).
- Seinfeld, J.H. and Pandis, S.N. (1998) Atmospheric chemistry and physics. From air pollution to climate change. New York, Wiley.
- Semb, A. (1978) Deposition of trace elements from the atmosphere in Norway. Ås, Norway, SNSF Project (SNSF FR 13/78).
- Semb, A., Bartonova, A., Schaug, J., Lükewille, A. og Tørseth, K. (1998) Pilot measurements of nitrogen containing species in air. Kjeller, Norwegian Institute for Air Research (EMEP/CCC-Report 5/98).
- Semb, A., Hanssen, J.E., Francois, F., Maenhaut, W. and Pacyna, J.M. (1995) Long range transport and deposition of mineral matter as a source for base cations. *Water Air Soil Pollut.*, 85, 1933-1940.
- Simpson, D., Winiwarter, W., Börjesson, G., Cinderby, S., Ferreira, A., Guenther, A., Hewitt, C.N., Janson, R., Khalil, M.A.K., Owen, S., Pierce, T.E., Puxbaum, H., Shearer, M., Skiba, U., Steinbrecher, R., Tarrason, L. and Öquist, M.G. (1999) Inventorying emissions from nature in Europe. *J. Geophys. Res.*, 104, No. D7, 8113-8152.
- Simpson, D. (1995) Biogenic emissions in Europe 2: Implications for ozone control strategies. *J. Geophys. Res.*, 100, No. D11, 22891-22906.
- Simpson, D. (1993) Photochemical model calculations over Europe for two extended summer periods: 1985 and 1989. Model results and comparisons with observations. *Atmos. Environ.*, 27A, No. 6, 921-943.
- Simpson, D. (1992) Long period modelling of photochemical oxidants in Europe. Calculations for July 1985. *Atmos. Environ.*, 26A, No. 9, 1609-1634.
- Tarrason, L. and Tsyro, S. (1998) Long-range transport of fine secondary particles, as presently estimated by the EMEP Lagrangian model. Oslo, Norwegian Meteorological Institute (EMEP/MS-C-W note 2/98) (Norwegian Meteorological Institute research report 69).
- Tsyro, S. and Erdman, L. (2000) Parameterisation of aerosol deposition processes in EMEP MSC-E and MSC-W transport models. Oslo, Norwegian Meteorological Institute (Joint EMEP MSC-E and MSC-W Note 7/00).
- WHO (1999) Particulate matter (PM₁₀ and PM_{2.5}). Results of intercomparison studies. Report on a WHO Workshop, Berlin 3-5 September 1998. Copenhagen, WHO Regional Office for Europe (EUR/ICP/EHB1040102, E62010, 10-13).
- WHO (1996) Revised WHO Air Quality Guidelines. Copenhagen, World Health Organization, Regional Office for Europe.

- WHO/UN-ECE LRTAP (1999) Health risk of particulate matter from long range transboundary air pollution. Preliminary Assessment. Bilthoven, WHO.
- Van der Zee, S.K., Hoek, G., Harssema, H. and Brunekreef, B. (1998) Characterization of particulate air pollution in urban and non-urban areas in the Netherlands. *Atmos. Environ.*, 32, 3717-3729.
- Vestreng, V. and Støren, E. (2000) Analysis of UNECE/EMEP Emission Data. MSC-W Status Report 2000. Oslo, Norwegian Meteorological Institute (EMEP/MS-CW Note 1/00).
- Zappoli, S., Andracchio, A., Fuzzi, S., Facchini, M.C., Gelencser, A., Kiss, G., Krivacsy, Z., Molnar, A., Meszaros, E., Hansson, H.-C., Rosman, K. and Zebuhr, Y. (1999) Inorganic, organic and macromolecular components of fine aerosol in different areas of Europe in relation to their water solubility. *Atmos. Environ.*, 33, 2733-2743.